

Williams®

16P-503-101  
Game No. 503  
April, 1981

# JUNGLE LORD



or service call TOLL-FREE:  
00-621-4765  
in Illinois call  
800-972-7898

Williams®   
ELECTRONICS, INC.

3401 N. California Ave., Chicago, IL 60618  
Cable Address: WILCOIN, CHICAGO  
(312) 267-2240



## FOREWORD

This instruction and drawing set provides essential installation information unique to JUNGLE LORD. For game operation, bookkeeping, game adjustment, diagnostic and self-test and basic troubleshooting procedures, refer to the instruction booklet located in the envelope inside the coin door. For detailed troubleshooting and interconnection information, refer to Williams Solid State Flipper Maintenance Manual and Supplements.

### SPECIAL CONSIDERATIONS WHEN REPLACING CIRCUIT BOARDS

#### CPU Board

1. Revision level 7 CPU Boards (batteries located on lower left corner at board) or later boards must be used.
2. Must be equipped with blue-labeled Flipper ROMs and blue-labeled Game ROMs.
3. Jumpers W3, W10, W11, W14, W17, W19, W20, and W22 must be connected. Jumpers W4, W9, W12, W15, W16, W18, W21, and W23 must be removed. With the exception of W25, (Factory Setting Jumper) all other jumpers are not changed.

#### Driver Board

Either earlier model D 7997 or later model D 8341 boards may be used. When earlier boards are used, switch matrix series resistors R204 thru R211 must be zero-ohm or be replaced with wire jumpers. Later D 8341 boards do not use series resistors in the switch matrix.

#### Sound Board

1. D 8224 required for speech
2. Must be jumpered for white-labeled sound ROM operation and be equipped with Sound ROM 3. (Jumpers W2, W5, W7, W9, W10, W12, and W15 connected; W3, W4, W6, W8, W11, and W13 removed).

#### Power Supply Board

1. D 8345 board (equipped with relay) is required.
2. F4 (20A SB) for flipper solenoids and magnets must be installed.

#### Display Boards

Model C 8363 Master Display and 7-digit Slave Displays required.

#### Optional Speech Module

Requires 5T5031 (IC7), 5T5032 (IC5), and 5T5033 (IC6) Speech ROMs.

### CONTENTS

Assembly and Interconnection .....	3/4
Inspection .....	3/4
Power Turn-On .....	5/6
Backbox Wiring Diagram .....	7
CPU Board Assembly Drawing .....	8
CPU Board Logic Diagram .....	9
Driver Board Assembly Drawing .....	10
Driver Board Logic Diagram (Sheet 1 of 2) .....	11
Driver Board Logic Diagram (Sheet 2 of 2) .....	13
Power Supply Assembly and Schematic Diagrams .....	14
Power Wiring Diagram .....	15
Sound Board Assembly Drawing .....	16
Sound Board Logic Diagram .....	17
C 8228 Speech Module Assembly and Logic Diagram	18
Insert Board Wiring Diagram .....	19
C 8363 Master Display Board Assembly Drawing .	20
C 8363 Master Display Board Logic Diagram ....	21
C 8364 and C 8365 Slave Display Boards Assembly and Schematic Diagrams .....	22
Cabinet Wiring Diagram .....	23
Playfield Lamp Wiring Diagram .....	24
Playfield Solenoid Wiring Diagram .....	25
Playfield Switch Wiring Diagram .....	26



# JUNGLE LORD

## SUMMARY OF FEATURES

In the Williams tradition, Jungle Lord is loaded with new features, both for player appeal and reliability. This summary sheet is provided to give you a better initial understanding of the game.

### PLAYER FEATURES

#### ① Double Trouble™ Scoring

The five bank drop targets located on the upper playfield start with one target showing. Hit that target and two targets appear; knock those down and three emerge, and on to four and then five. Demolishing the last sequence of five targets qualifies the player for **Double Trouble** scoring. A single target pops up; make it for 10,000 and **Double Trouble** targets pop up one at a time at random and must be hit within a certain time period before they drop. The first target hit collects 20,000 points, doubles to 40,000 for the second target, on to 80,000 for the third, to a maximum of 160,000. Any target not hit in time drops the scoring back to 10,000. For even more interesting playfield action, it is even possible to achieve 2X scoring with **Double Trouble**.

#### ② Multi-Ball™ Play

The mini-playfield with a captive mini-ball and four lanes spell out LORD. Making one of the two upper playfield eject holes kicks the mini-ball out to roll down one of the four lanes lighting a letter in LORD. Going down the #4 inside rollover lights the red arrow at the bottom of the right ramp; going up the ramp into the eject hole gives two kids on the mini-playfield. Completing a lower playfield 3-bank (adjustable) also spots a letter in LORD. When LORD is completely lit, **Multi-Ball** play is enabled. A shot to either of the two top playfield eject holes locks up the ball in play. A second ball is released to be shot onto the playfield. As soon as the second ball is shot, the eject hole releases the locked up ball for 2-ball, 35 second (adjustable) **Multi-Ball** play. Should one of the two balls drain with time left, then another shot to the eject hole will kick out the drained ball for more **Multi-Ball** shooting time. Completely re-lighting LORD during **Multi-Ball** play scores Special.

#### ③ Magna-Save™ Feature

Hitting any drop target on the lower level banks will light timer lights for the **Magna Save** feature. Build up to five time units on each side of the playfield for use in saving draining balls. Players direct the number of seconds used for **Magna Save** via the left and right red control buttons forward of the flipper control buttons for spectacular playfield saves.

#### ④ 2X Scoring

Hitting the variously placed number targets and rollovers clearly marked 1, 2, 3, 4, and 5 with one ball gives a shooter double scoring for the remainder of that balls play.

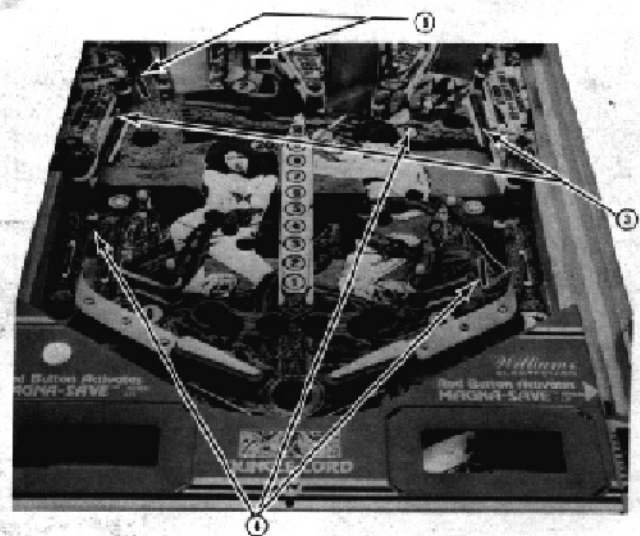
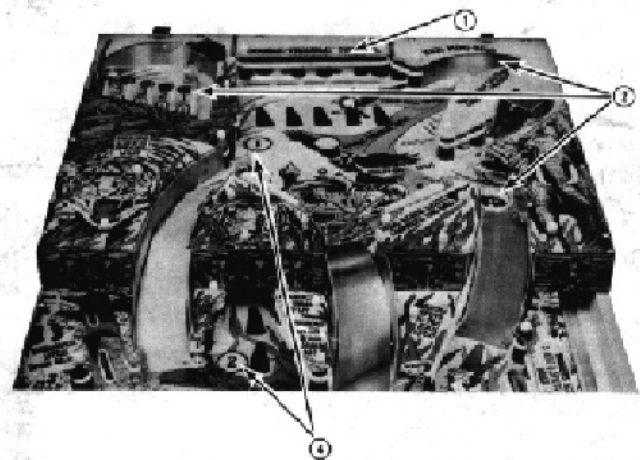

#### ⑤ Bonus X and Drain Shield

The inside bottom rollover lanes, marked 4 and 5, light the timed green arrow located in front of the turnaround for bonus multiplier. Making the turnaround shot within a certain period of time collects 2X, 3X, 5X to 10X. When 10X is made, if the ball rolls down either rollover lane again, the amber arrow in front of the horseshoe is lit and that spots the left or right drain shield. Whenever the drain shield is lit and the ball drains on the lit side, the ball is returned to the shooter and play continues. Making the horseshoe through the difficult left entrance shot gives a player an automatic drain shield.

## TECHNICAL FEATURES

### Drop Targets

5-Bank targets are individually reset and simultaneously released similar to Alien Poker drop targets to allow drop target memory. 3 Bank targets are similar to those used in Black Knight. Both types of target banks use blade-type switches that remain closed with the target down.

### Ball Ramp Mechanism

For the 2-Ball **Multi-Ball** feature, microswitches are used on the ball ramp. These switch mechanisms are essentially adjustment-free and will provide problem-free operation.

### Lower Flippers Hotter

The power for the upper playfield flippers is routed through the lower flipper EOS switches. No power to an upper flipper until the lower flipper EOS switch opens means stronger lower playfield flippers. Power for the upper flippers is in series with the low-impedance lower flipper pull-in winding, providing weaker action appropriate to the small upper playfield.

### New Design Power Supply Board

The fuse card is gone; the Special "BLACKOUT" relay is mounted on the board. General Illumination 6.3 VAC is routed through the Power Supply.

### Driver Board

As in Black Knight, complex playfield features result in numerous closed switches. This requires that the switch matrix column drive series resistors (R204 thru R211) on the Driver Board be replaced with zero-ohm resistors or jumpers.

## PLAY ADJUSTMENTS

Function 31 - **Multi-Ball** timer - Continuously adjustable from 15 to 99 seconds. Adjusting the timer affects average ball time and the difficulty of winning a special. The factory recommended setting is 35 seconds.

Function 32 - **Special Difficulty** - The moderate factory setting of 00 allows letters in LORD to be spotted during **Multi-Ball** play by completing a 3-bank, with the conservative 01 setting, letters in LORD are spotted only from the mini-playfield during **Multi-ball** play.

Function 33 - **Double Trouble** timing - This adjustment controls the time a player has to make the **Double Trouble** drop target before it is released. Setting it to a higher number results in increased player scores; a lower setting in decreased player scores.

Function 34 - **Double Trouble** reset timing (0-99) - This adjustment controls the "penalty" time before a target is reset when not made before it is released during a **Double Trouble** scoring sequence.

Function 35 - **Multi-Ball** play difficulty - With conservative 01 setting, the last letter in LORD cannot be spotted by completing a 3-bank of drop targets. This will make achieving **Multi-Ball** play more difficult.



### Assembly and Interconnection

With legs attached to cabinet and backbox positioned face-down on top of cabinet with the opening facing the rear of the cabinet proceed as follows:

- A. Pull five cables from backbox.
- B. Reach into right side of pedestal hole, pull up ground strap, and push it into backbox.
- C. Remove ties securing cabinet and playfield cables to cabinet and pull up these cables.
- D. Interconnect five cables. They are size and color coded.
- E. Insert line cord into notch in cabinet. DO NOT PLUG IN AT THIS TIME.
- F. Push remote volume control cable, White-Red solenoid ground cable, and transformer cable (terminated with four plugs) into backbox.
- G. Lift up backbox and position on cabinet pedestal, engaging brackets for support.
- H. Remove shipping blocks from insert door.
- I. Secure backbox to cabinet using two bolts and washers.
- J. Connect ground braid and White-Red wires under wing nut and washer at bottom of backbox.
- K. Loosely position remote volume cable and Sound Board power cable in harness and plug connector into 10J4 and 10J1, respectively.
- L. Connect bridge rectifier connector 6P1/6J1, and plug remaining two transformer connections into 3J1 and 3J9 on the Power Supply Board.

### Inspection

- A. Check all connectors in backbox for loose wire termination. Reseat any loose wires by pushing in on the terminal.
- B. Push on all connectors attached to Master Display, CPU, Driver, and Sound Boards, and check terminations on capacitor and bridge rectifier at the lower right of the backbox.
- C. Gently press on all the socketed IC packages on the CPU and Sound Boards.
- D. Check that two fuses on the Sound Board, seven fuses on Power Supply Board, and two fuses on Insert Board are secure.
- E. Push on the connector attached to Slave Display Boards.
- F. Check that the line fuse in the bottom of the cabinet is secure.
- G. Check the transformer input connector in bottom of cabinet for loose wire termination. Reseat any loose wires by pushing in on the termination.
- H. Check the cabinet to coin door connector for loose wire termination. Reseat any loose wires by pushing in on the termination.



### Power Turn-On and Game Setup

This machine **MUST BE PLUGGED** INTO A PROPERLY GROUNDED OUTLET to PREVENT SHOCK HAZARD to ensure PROPER GAME OPERATION. DO NOT use a "cheater" plug to defeat the ground pin on the line cord, and DO NOT cut off the ground pin. The line voltage **MUST** agree with that specified on the back of the cabinet or serious damage to the machine could occur. For low-line applications (105 or 210V ac), refer to the power wiring diagram.

1. With the coin door closed, plug the game in and turn it ON. The game should come on in the game over mode as indicated by the player 1 score reading zero, game over lights lit, and the high score to date alternating with the player scores.
2. If the game comes on in the diagnostic mode (number of credits display showing 04, ball in play display showing 00, and player 1 display showing game identification) turn the game OFF and ON again.
  - a. If the game now comes on in the game over mode the bookkeeping and game evaluation totals have been reset to zero.
  - b. If the game still comes on in the diagnostic mode, open the coin door and turn the game OFF, and ON twice. This is an indication of the batteries being removed with the power OFF or coming loose during shipment. This has also resulted in features reverting to factory settings. Any changes from factory settings must be reentered using procedures provided in the instruction booklet.
3. If the game still comes on in the diagnostic mode, refer to troubleshooting procedures in the maintenance manual.
4. Insert mini-ball through opening in plastic at the upper left corner of the upper playfield and place two balls on playfield next to outhole.
5. Perform diagnostic tests and make any desired changes to features as described in the instruction booklet.



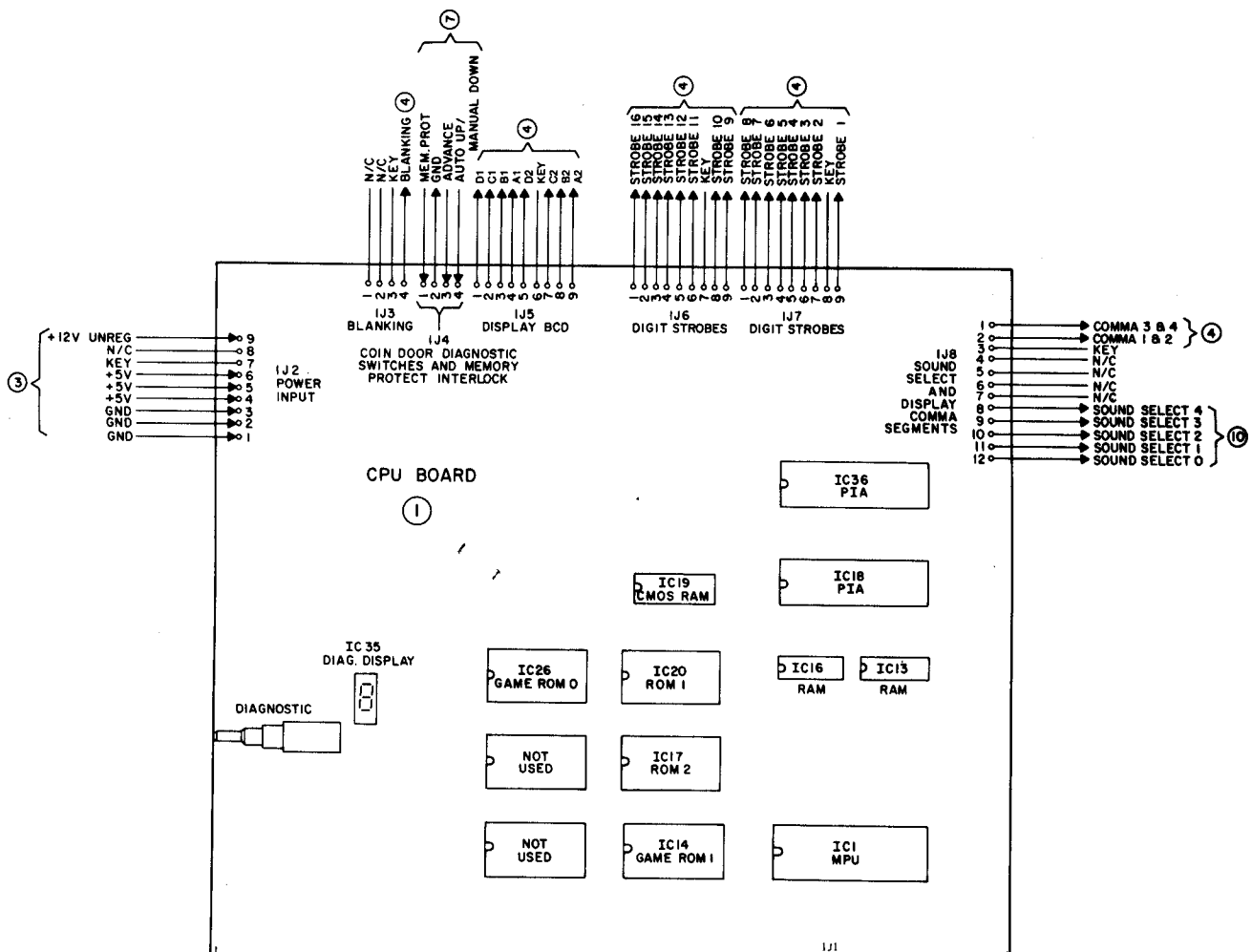







TP1 +12V. UNREG.

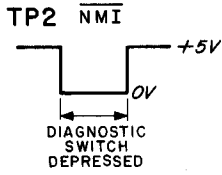

TP3 MEMORY PROTECT

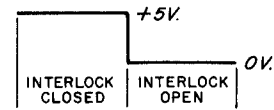

TP4 BLANKING

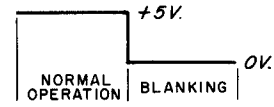

TP5 IRQ

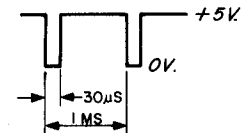

TP6 BUS φ2

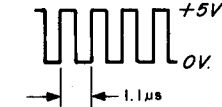

TP7 CMOS RAM B+

POWER ON 4.3K  
POWER OFF 3.9K

TP8 RESET

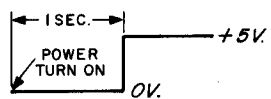

TP9 +5V.

TP10 GND

DISPLAY BLANKING

MEM. PROTECT & DIAGNOSTIC SW

MASTER DISPLAY BCD OUTPUTS

MASTER DISPLAY

LOGIC POWER BUS INPUT

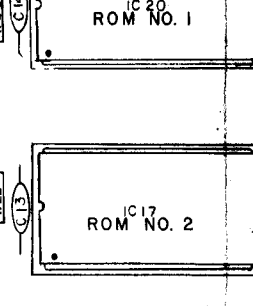
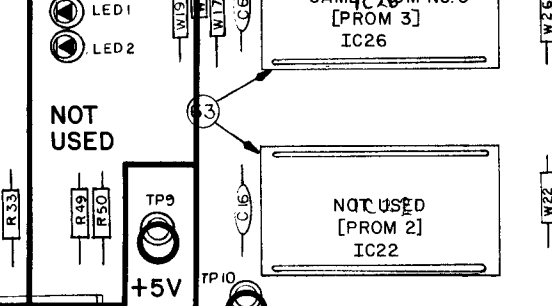
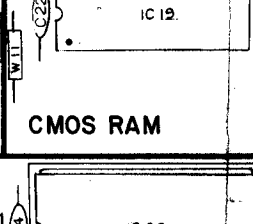
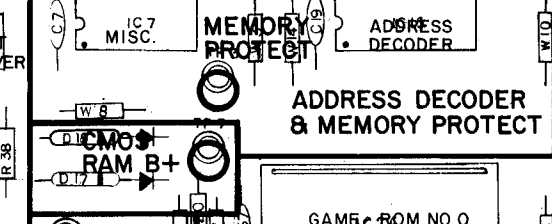
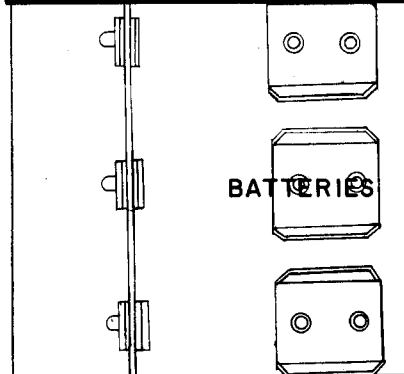
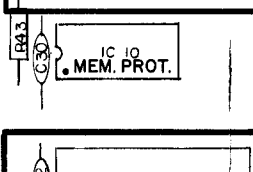
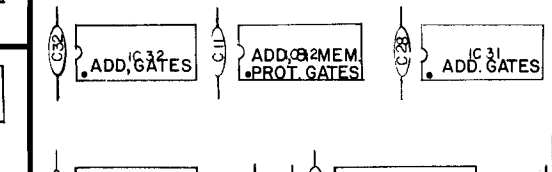
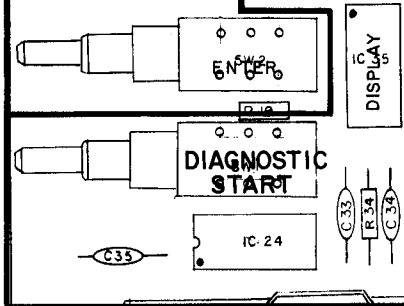
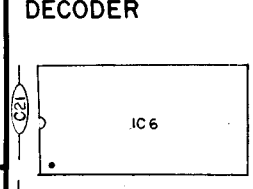
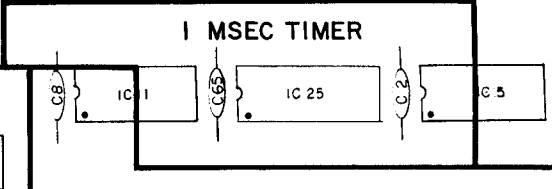
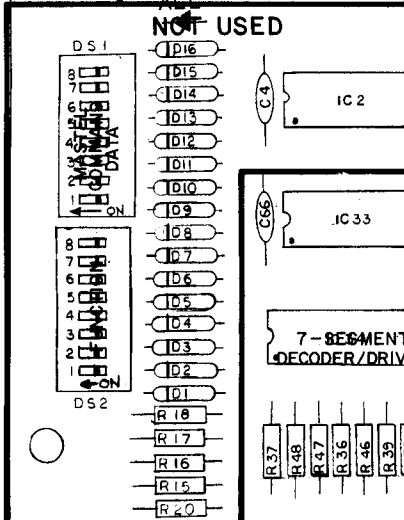
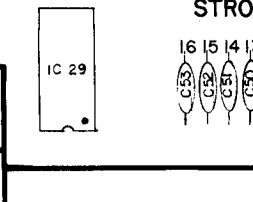
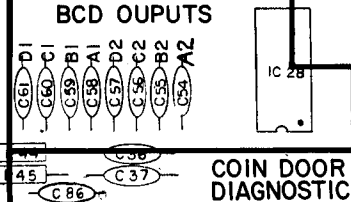
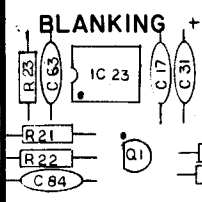
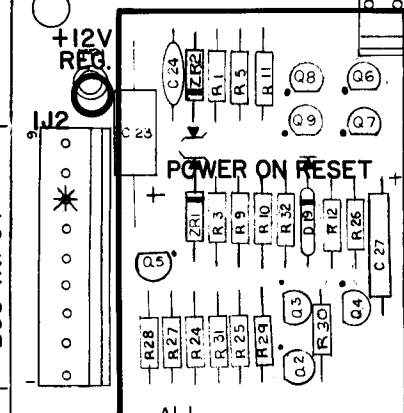







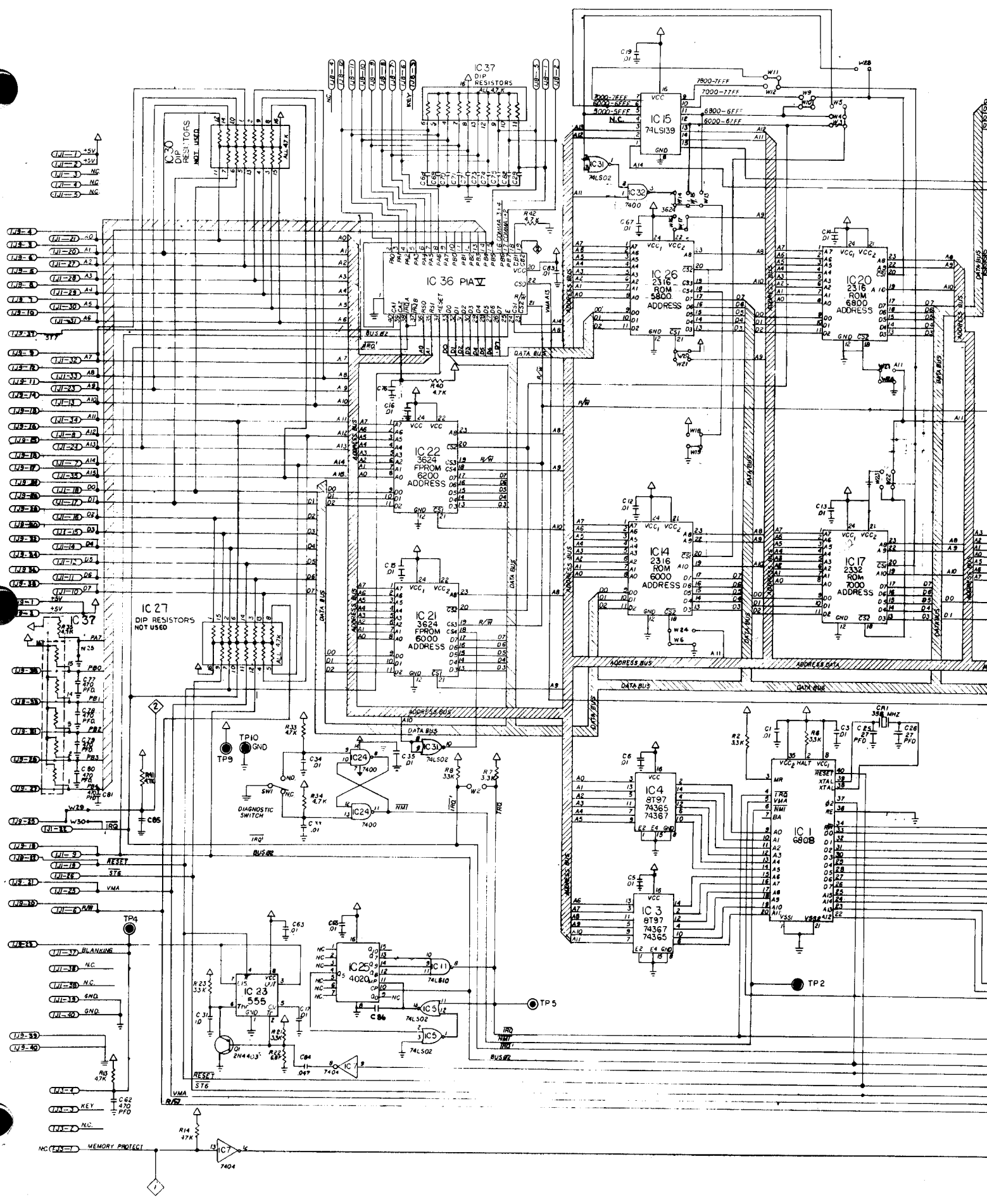

- (U1-1) +5V
- (U1-2) +5V
- (U1-3) +5V
- (U1-4) NC
- (U1-5) NC

- (U2-4) (U1-2) A0
- (U2-5) (U1-2) A1
- (U2-6) (U1-2) A2
- (U2-7) (U1-2) A3
- (U2-8) (U1-2) A4
- (U2-9) (U1-2) A5
- (U2-10) (U1-2) A6
- (U2-11) 5V
- (U2-12) (U1-2) A7
- (U2-13) (U1-2) A8
- (U2-14) (U1-2) A9
- (U2-15) (U1-2) A10
- (U2-16) (U1-2) A11
- (U2-17) (U1-2) A12
- (U2-18) (U1-2) A13
- (U2-19) (U1-2) A14
- (U2-20) (U1-2) A15
- (U2-21) (U1-2) A16
- (U2-22) (U1-2) A17
- (U2-23) (U1-2) A18
- (U2-24) (U1-2) A19
- (U2-25) (U1-2) A20
- (U2-26) (U1-2) A21
- (U2-27) (U1-2) A22
- (U2-28) (U1-2) A23
- (U2-29) (U1-2) A24
- (U2-30) (U1-2) A25
- (U2-31) (U1-2) A26
- (U2-32) (U1-2) A27
- (U2-33) (U1-2) A28
- (U2-34) (U1-2) A29
- (U2-35) (U1-2) A30
- (U2-36) (U1-2) A31
- (U2-37) (U1-2) A32
- (U2-38) (U1-2) A33
- (U2-39) (U1-2) A34
- (U2-40) (U1-2) A35
- (U2-41) (U1-2) A36
- (U2-42) (U1-2) A37
- (U2-43) (U1-2) A38
- (U2-44) (U1-2) A39
- (U2-45) (U1-2) A40
- (U2-46) (U1-2) A41
- (U2-47) (U1-2) A42
- (U2-48) (U1-2) A43
- (U2-49) (U1-2) A44
- (U2-50) (U1-2) A45
- (U2-51) (U1-2) A46
- (U2-52) (U1-2) A47
- (U2-53) (U1-2) A48
- (U2-54) (U1-2) A49
- (U2-55) (U1-2) A50
- (U2-56) (U1-2) A51
- (U2-57) (U1-2) A52
- (U2-58) (U1-2) A53
- (U2-59) (U1-2) A54
- (U2-60) (U1-2) A55
- (U2-61) (U1-2) A56
- (U2-62) (U1-2) A57
- (U2-63) (U1-2) A58
- (U2-64) (U1-2) A59
- (U2-65) (U1-2) A60
- (U2-66) (U1-2) A61
- (U2-67) (U1-2) A62
- (U2-68) (U1-2) A63
- (U2-69) (U1-2) A64
- (U2-70) (U1-2) A65
- (U2-71) (U1-2) A66
- (U2-72) (U1-2) A67
- (U2-73) (U1-2) A68
- (U2-74) (U1-2) A69
- (U2-75) (U1-2) A70
- (U2-76) (U1-2) A71
- (U2-77) (U1-2) A72
- (U2-78) (U1-2) A73
- (U2-79) (U1-2) A74
- (U2-80) (U1-2) A75
- (U2-81) (U1-2) A76
- (U2-82) (U1-2) A77
- (U2-83) (U1-2) A78
- (U2-84) (U1-2) A79
- (U2-85) (U1-2) A80
- (U2-86) (U1-2) A81
- (U2-87) (U1-2) A82
- (U2-88) (U1-2) A83
- (U2-89) (U1-2) A84
- (U2-90) (U1-2) A85
- (U2-91) (U1-2) A86
- (U2-92) (U1-2) A87
- (U2-93) (U1-2) A88
- (U2-94) (U1-2) A89
- (U2-95) (U1-2) A90
- (U2-96) (U1-2) A91
- (U2-97) (U1-2) A92
- (U2-98) (U1-2) A93
- (U2-99) (U1-2) A94
- (U2-100) (U1-2) A95
- (U3-1) (U1-2) A0
- (U3-2) (U1-2) A1
- (U3-3) (U1-2) A2
- (U3-4) (U1-2) A3
- (U3-5) (U1-2) A4
- (U3-6) (U1-2) A5
- (U3-7) (U1-2) A6
- (U3-8) (U1-2) A7
- (U3-9) (U1-2) A8
- (U3-10) (U1-2) A9
- (U3-11) (U1-2) A10
- (U3-12) (U1-2) A11
- (U3-13) (U1-2) A12
- (U3-14) (U1-2) A13
- (U3-15) (U1-2) A14
- (U3-16) (U1-2) A15
- (U3-17) (U1-2) A16
- (U3-18) (U1-2) A17
- (U3-19) (U1-2) A18
- (U3-20) (U1-2) A19
- (U3-21) (U1-2) A20
- (U3-22) (U1-2) A21
- (U3-23) (U1-2) A22
- (U3-24) (U1-2) A23
- (U3-25) (U1-2) A24
- (U3-26) (U1-2) A25
- (U3-27) (U1-2) A26
- (U3-28) (U1-2) A27
- (U3-29) (U1-2) A28
- (U3-30) (U1-2) A29
- (U3-31) (U1-2) A30
- (U3-32) (U1-2) A31
- (U3-33) (U1-2) A32
- (U3-34) (U1-2) A33
- (U3-35) (U1-2) A34
- (U3-36) (U1-2) A35
- (U3-37) (U1-2) A36
- (U3-38) (U1-2) A37
- (U3-39) (U1-2) A38
- (U3-40) (U1-2) A39
- (U3-41) (U1-2) A40
- (U3-42) (U1-2) A41
- (U3-43) (U1-2) A42
- (U3-44) (U1-2) A43
- (U3-45) (U1-2) A44
- (U3-46) (U1-2) A45
- (U3-47) (U1-2) A46
- (U3-48) (U1-2) A47
- (U3-49) (U1-2) A48
- (U3-50) (U1-2) A49
- (U3-51) (U1-2) A50
- (U3-52) (U1-2) A51
- (U3-53) (U1-2) A52
- (U3-54) (U1-2) A53
- (U3-55) (U1-2) A54
- (U3-56) (U1-2) A55
- (U3-57) (U1-2) A56
- (U3-58) (U1-2) A57
- (U3-59) (U1-2) A58
- (U3-60) (U1-2) A59
- (U3-61) (U1-2) A60
- (U3-62) (U1-2) A61
- (U3-63) (U1-2) A62
- (U3-64) (U1-2) A63
- (U3-65) (U1-2) A64
- (U3-66) (U1-2) A65
- (U3-67) (U1-2) A66
- (U3-68) (U1-2) A67
- (U3-69) (U1-2) A68
- (U3-70) (U1-2) A69
- (U3-71) (U1-2) A70
- (U3-72) (U1-2) A71
- (U3-73) (U1-2) A72
- (U3-74) (U1-2) A73
- (U3-75) (U1-2) A74
- (U3-76) (U1-2) A75
- (U3-77) (U1-2) A76
- (U3-78) (U1-2) A77
- (U3-79) (U1-2) A78
- (U3-80) (U1-2) A79
- (U3-81) (U1-2) A80
- (U3-82) (U1-2) A81
- (U3-83) (U1-2) A82
- (U3-84) (U1-2) A83
- (U3-85) (U1-2) A84
- (U3-86) (U1-2) A85
- (U3-87) (U1-2) A86
- (U3-88) (U1-2) A87
- (U3-89) (U1-2) A88
- (U3-90) (U1-2) A89
- (U3-91) (U1-2) A90
- (U3-92) (U1-2) A91
- (U3-93) (U1-2) A92
- (U3-94) (U1-2) A93
- (U3-95) (U1-2) A94
- (U3-96) (U1-2) A95
- (U3-97) (U1-2) A96
- (U3-98) (U1-2) A97
- (U3-99) (U1-2) A98
- (U3-100) (U1-2) A99
- (U4-1) (U1-2) A0
- (U4-2) (U1-2) A1
- (U4-3) (U1-2) A2
- (U4-4) (U1-2) A3
- (U4-5) (U1-2) A4
- (U4-6) (U1-2) A5
- (U4-7) (U1-2) A6
- (U4-8) (U1-2) A7
- (U4-9) (U1-2) A8
- (U4-10) (U1-2) A9
- (U4-11) (U1-2) A10
- (U4-12) (U1-2) A11
- (U4-13) (U1-2) A12
- (U4-14) (U1-2) A13
- (U4-15) (U1-2) A14
- (U4-16) (U1-2) A15
- (U4-17) (U1-2) A16
- (U4-18) (U1-2) A17
- (U4-19) (U1-2) A18
- (U4-20) (U1-2) A19
- (U4-21) (U1-2) A20
- (U4-22) (U1-2) A21
- (U4-23) (U1-2) A22
- (U4-24) (U1-2) A23
- (U4-25) (U1-2) A24
- (U4-26) (U1-2) A25
- (U4-27) (U1-2) A26
- (U4-28) (U1-2) A27
- (U4-29) (U1-2) A28
- (U4-30) (U1-2) A29
- (U4-31) (U1-2) A30
- (U4-32) (U1-2) A31
- (U4-33) (U1-2) A32
- (U4-34) (U1-2) A33
- (U4-35) (U1-2) A34
- (U4-36) (U1-2) A35
- (U4-37) (U1-2) A36
- (U4-38) (U1-2) A37
- (U4-39) (U1-2) A38
- (U4-40) (U1-2) A39
- (U4-41) (U1-2) A40
- (U4-42) (U1-2) A41
- (U4-43) (U1-2) A42
- (U4-44) (U1-2) A43
- (U4-45) (U1-2) A44
- (U4-46) (U1-2) A45
- (U4-47) (U1-2) A46
- (U4-48) (U1-2) A47
- (U4-49) (U1-2) A48
- (U4-50) (U1-2) A49
- (U4-51) (U1-2) A50
- (U4-52) (U1-2) A51
- (U4-53) (U1-2) A52
- (U4-54) (U1-2) A53
- (U4-55) (U1-2) A54
- (U4-56) (U1-2) A55
- (U4-57) (U1-2) A56
- (U4-58) (U1-2) A57
- (U4-59) (U1-2) A58
- (U4-60) (U1-2) A59
- (U4-61) (U1-2) A60
- (U4-62) (U1-2) A61
- (U4-63) (U1-2) A62
- (U4-64) (U1-2) A63
- (U4-65) (U1-2) A64
- (U4-66) (U1-2) A65
- (U4-67) (U1-2) A66
- (U4-68) (U1-2) A67
- (U4-69) (U1-2) A68
- (U4-70) (U1-2) A69
- (U4-71) (U1-2) A70
- (U4-72) (U1-2) A71
- (U4-73) (U1-2) A72
- (U4-74) (U1-2) A73
- (U4-75) (U1-2) A74
- (U4-76) (U1-2) A75
- (U4-77) (U1-2) A76
- (U4-78) (U1-2) A77
- (U4-79) (U1-2) A78
- (U4-80) (U1-2) A79
- (U4-81) (U1-2) A80
- (U4-82) (U1-2) A81
- (U4-83) (U1-2) A82
- (U4-84) (U1-2) A83
- (U4-85) (U1-2) A84
- (U4-86) (U1-2) A85
- (U4-87) (U1-2) A86
- (U4-88) (U1-2) A87
- (U4-89) (U1-2) A88
- (U4-90) (U1-2) A89
- (U4-91) (U1-2) A90
- (U4-92) (U1-2) A91
- (U4-93) (U1-2) A92
- (U4-94) (U1-2) A93
- (U4-95) (U1-2) A94
- (U4-96) (U1-2) A95
- (U4-97) (U1-2) A96
- (U4-98) (U1-2) A97
- (U4-99) (U1-2) A98
- (U4-100) (U1-2) A99
- (U5-1) (U1-2) A0
- (U5-2) (U1-2) A1
- (U5-3) (U1-2) A2
- (U5-4) (U1-2) A3
- (U5-5) (U1-2) A4
- (U5-6) (U1-2) A5
- (U5-7) (U1-2) A6
- (U5-8) (U1-2) A7
- (U5-9) (U1-2) A8
- (U5-10) (U1-2) A9
- (U5-11) (U1-2) A10
- (U5-12) (U1-2) A11
- (U5-13) (U1-2) A12
- (U5-14) (U1-2) A13
- (U5-15) (U1-2) A14
- (U5-16) (U1-2) A15
- (U5-17) (U1-2) A16
- (U5-18) (U1-2) A17
- (U5-19) (U1-2) A18
- (U5-20) (U1-2) A19
- (U5-21) (U1-2) A20
- (U5-22) (U1-2) A21
- (U5-23) (U1-2) A22
- (U5-24) (U1-2) A23
- (U5-25) (U1-2) A24
- (U5-26) (U1-2) A25
- (U5-27) (U1-2) A26
- (U5-28) (U1-2) A27
- (U5-29) (U1-2) A28
- (U5-30) (U1-2) A29
- (U5-31) (U1-2) A30
- (U5-32) (U1-2) A31
- (U5-33) (U1-2) A32
- (U5-34) (U1-2) A33
- (U5-35) (U1-2) A34
- (U5-36) (U1-2) A35
- (U5-37) (U1-2) A36
- (U5-38) (U1-2) A37
- (U5-39) (U1-2) A38
- (U5-40) (U1-2) A39
- (U5-41) (U1-2) A40
- (U5-42) (U1-2) A41
- (U5-43) (U1-2) A42
- (U5-44) (U1-2) A43
- (U5-45) (U1-2) A44
- (U5-46) (U1-2) A45
- (U5-47) (U1-2) A46
- (U5-48) (U1-2) A47
- (U5-49) (U1-2) A48
- (U5-50) (U1-2) A49
- (U5-51) (U1-2) A50
- (U5-52) (U1-2) A51
- (U5-53) (U1-2) A52
- (U5-54) (U1-2) A53
- (U5-55) (U1-2) A54
- (U5-56) (U1-2) A55
- (U5-57) (U1-2) A56
- (U5-58) (U1-2) A57
- (U5-59) (U1-2) A58
- (U5-60) (U1-2) A59
- (U5-61) (U1-2) A60
- (U5-62) (U1-2) A61
- (U5-63) (U1-2) A62
- (U5-64) (U1-2) A63
- (U5-65) (U1-2) A64
- (U5-66) (U1-2) A65
- (U5-67) (U1-2) A66
- (U5-68) (U1-2) A67
- (U5-69) (U1-2) A68
- (U5-70) (U1-2) A69
- (U5-71) (U1-2) A70
- (U5-72) (U1-2) A71
- (U5-73) (U1-2) A72
- (U5-74) (U1-2) A73
- (U5-75) (U1-2) A74
- (U5-76) (U1-2) A75
- (U5-77) (U1-2) A76
- (U5-78) (U1-2) A77
- (U5-79) (U1-2) A78
- (U5-80) (U1-2) A79
- (U5-81) (U1-2) A80
- (U5-82) (U1-2) A81
- (U5-83) (U1-2) A82
- (U5-84) (U1-2) A83
- (U5-85) (U1-2) A84
- (U5-86) (U1-2) A85
- (U5-87) (U1-2) A86
- (U5-88) (U1-2) A87
- (U5-89) (U1-2) A88
- (U5-90) (U1-2) A89
- (U5-91) (U1-2) A90
- (U5-92) (U1-2) A91
- (U5-93) (U1-2) A92
- (U5-94) (U1-2) A93
- (U5-95) (U1-2) A94
- (U5-96) (U1-2) A95
- (U5-97) (U1-2) A96
- (U5-98) (U1-2) A97
- (U5-99) (U1-2) A98
- (U5-100) (U1-2) A99
- (U6-1) (U1-2) A0
- (U6-2) (U1-2) A1
- (U6-3) (U1-2) A2
- (U6-4) (U1-2) A3
- (U6-5) (U1-2) A4
- (U6-6) (U1-2) A5
- (U6-7) (U1-2) A6
- (U6-8) (U1-2) A7
- (U6-9) (U1-2) A8
- (U6-10) (U1-2) A9
- (U6-11) (U1-2) A10
- (U6-12) (U1-2) A11
- (U6-13) (U1-2) A12
- (U6-14) (U1-2) A13
- (U6-15) (U1-2) A14
- (U6-16) (U1-2) A15
- (U6-17) (U1-2) A16
- (U6-18) (U1-2) A17
- (U6-19) (U1-2) A18
- (U6-20) (U1-2) A19
- (U6-21) (U1-2) A20
- (U6-22) (U1-2) A21
- (U6-23) (U1-2) A22
- (U6-24) (U1-2) A23
- (U6-25) (U1-2) A24
- (U6-26) (U1-2) A25
- (U6-27) (U1-2) A26
- (U6-28) (U1-2) A27
- (U6-29) (U1-2) A28
- (U6-30) (U1-2) A29
- (U6-31) (U1-2) A30
- (U6-32) (U1-2) A31
- (U6-33) (U1-2) A32
- (U6-34) (U1-2) A33
- (U6-35) (U1-2) A34
- (U6-36) (U1-2) A35
- (U6-37) (U1-2) A36
- (U6-38) (U1-2) A37
- (U6-39) (U1-2) A38
- (U6-40) (U1-2) A39
- (U6-41) (U1-2) A40
- (U6-42) (U1-2) A41
- (U6-43) (U1-2) A42
- (U6-44) (U1-2) A43
- (U6-45) (U1-2) A44
- (U6-46) (U1-2) A45
- (U6-47) (U1-2) A46
- (U6-48) (U1-2) A47
- (U6-49) (U1-2) A48
- (U6-50) (U1-2) A49
- (U6-51) (U1-2) A50
- (U6-52) (U1-2) A51
- (U6-53) (U1-2) A52
- (U6-54) (U1-2) A53
- (U6-55) (U1-2) A54
- (U6-56) (U1-2) A55
- (U6-57) (U1-2) A56
- (U6-58) (U1-2) A57
- (U6-59) (U1-2) A58
- (U6-60) (U1-2) A59
- (U6-61) (U1-2) A60
- (U6-62) (U1-2) A61
- (U6-63) (U1-2) A62
- (U6-64) (U1-2) A63
- (U6-65) (U1-2) A64
- (U6-66) (U1-2) A65
- (U6-67) (U1-2) A66
- (U6-68) (U1-2) A67
- (U6-69) (U1-2) A68
- (U6-70) (U1-2) A69
- (U6-71) (U1-2) A70
- (U6-72) (U1-2) A71
- (U6-73) (U1-2) A



NOTES:

1. ALL RESISTORS, 1/4 WATT UNLESS NOTED OTHERWISE.
2. ALL CAPACITORS, MFD. UNLESS NOTED OTHERWISE.
3. WHEN USING WHITE, YELLOW OR GREEN LABEL PROGRAMS REMOVE -W10,W11,W14,W17,W19,W20,W22 CONNECT: W9,W12,W15,W16,W18,W21,W23 FOR FIREPOWER ONLY- ALSO REMOVE W3 & CONNECT W4.

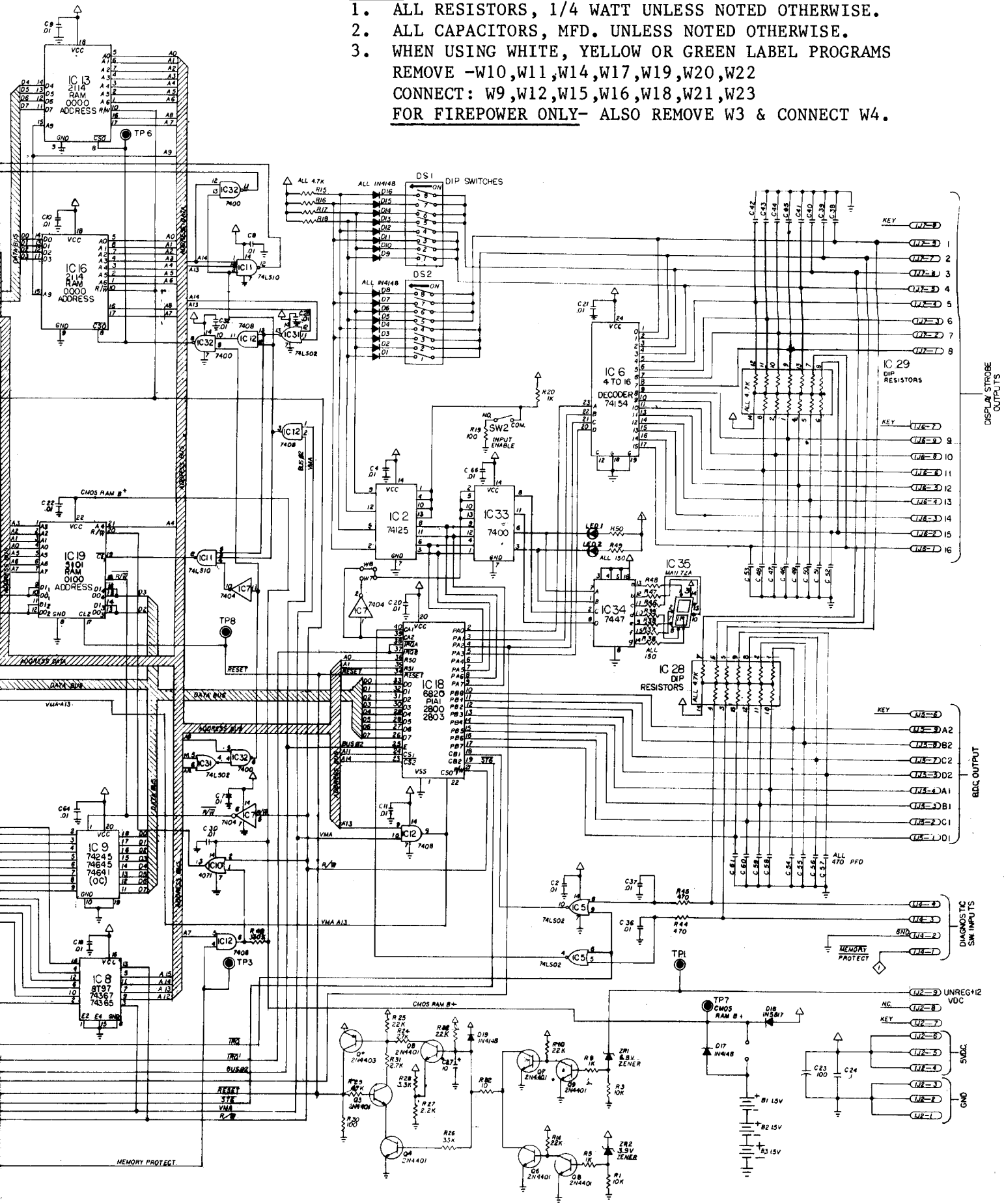

CPU Board Logic Diagram



REVISION LETTER	REVISION
C	REVISED AND REDRAWN R. GAY 11-28-77
D	ITEM NO. 28, PT. NO. WAS 5A-8959 & ADDED MOUNTING NOTE FOR R149 THRU R156. R. GAY 4-11-78
E	DELETED ITEM NO. 36, PT. NO. 5A-8985 E.C.O. R. GAY 9-12-78
F	ADDED ITEM NO. 36 & ITEM NO. 22, DELETED (8) RESISTORS & QTY WAS 32 E.C.O. 4624 R. GAY 10-4-78

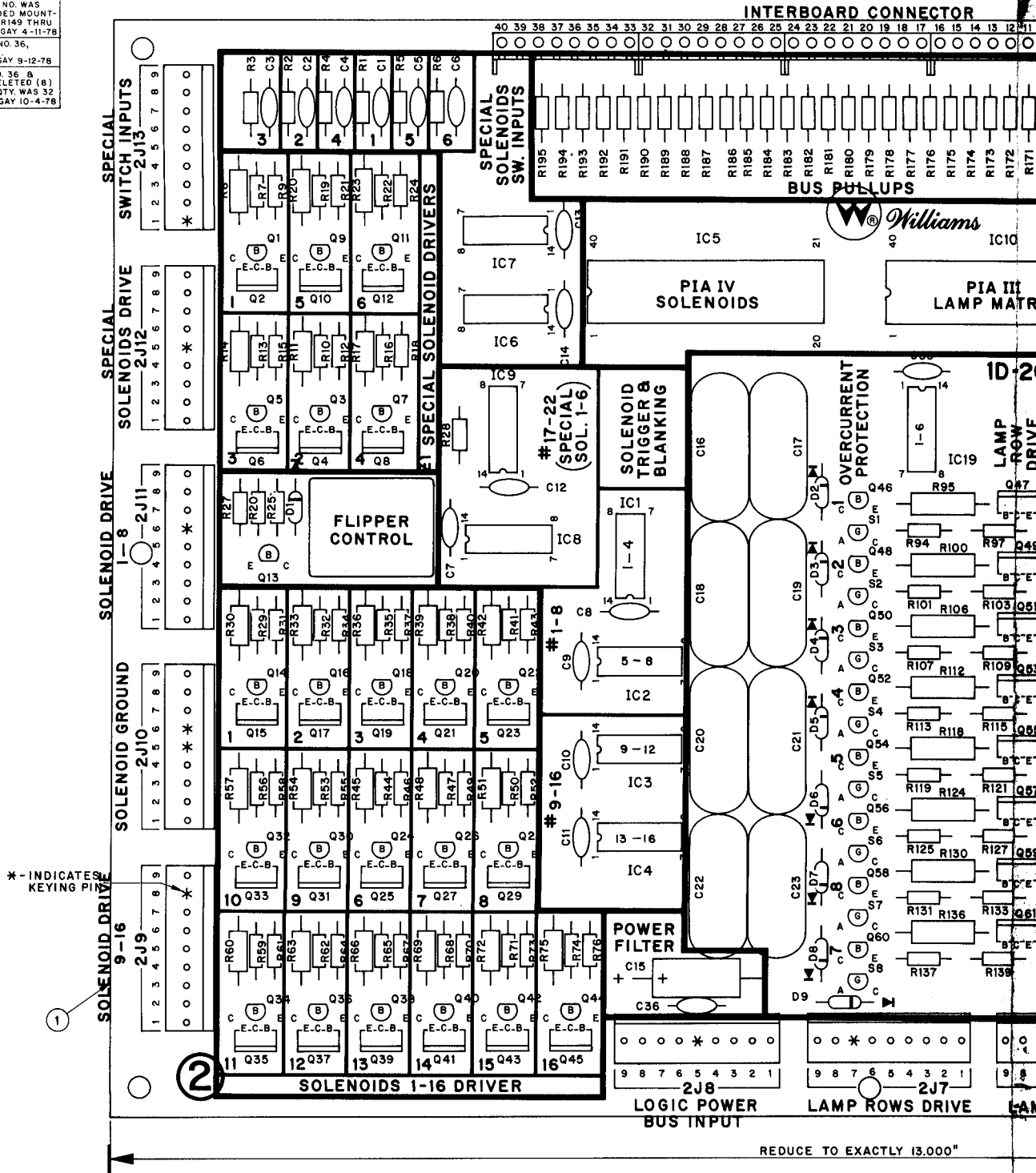

REDUCE TO EXACTLY 13.000"



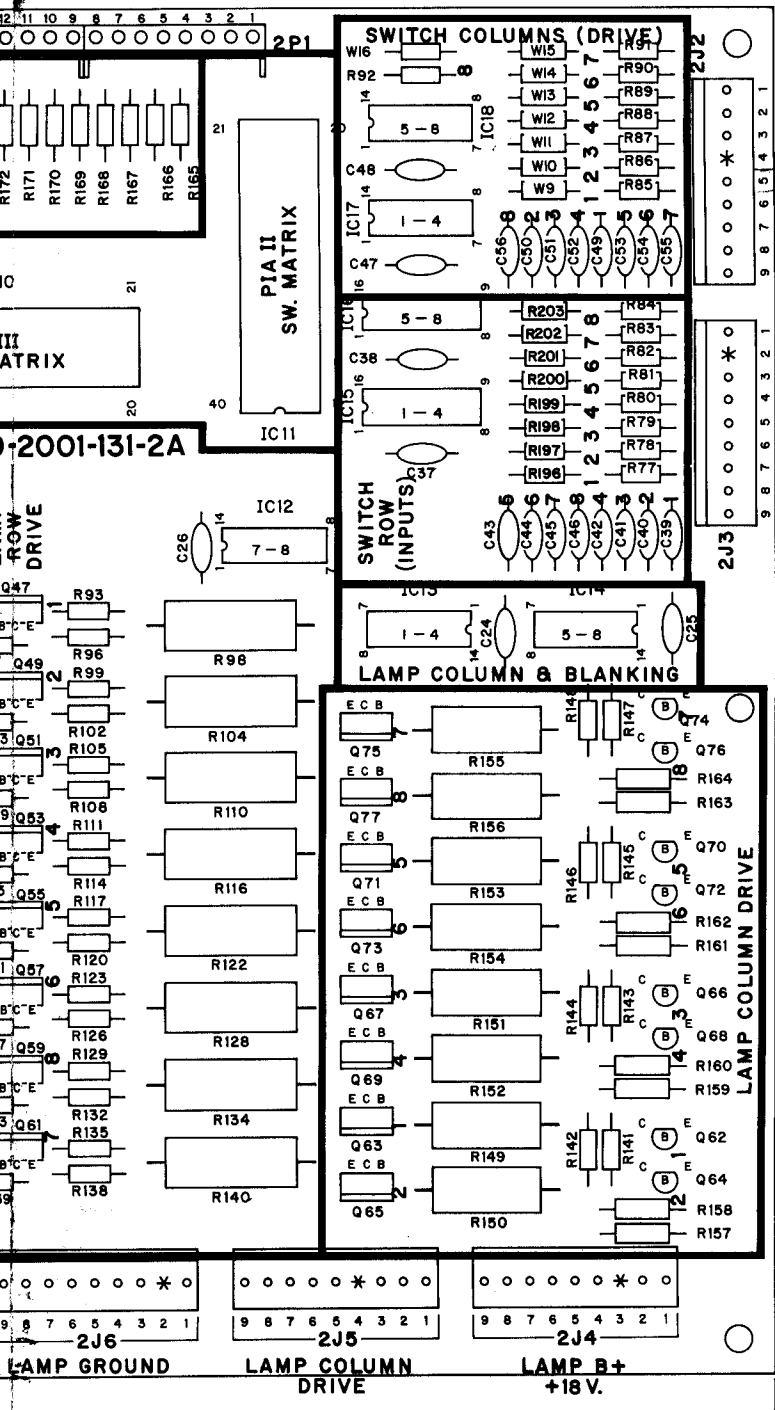

**BILL OF MATERIAL**

ITEM NO.	PART NO.	PART DESIGNATION	DESCRIPTION	REQ'D. NO.
1	18-2001-131		BARE P.C. BOARD	1
2	5A-8948	IC8, IC9	N7402 QUADRUPLE 2 INPUT POSITIVE NOR GATE	2
3	5A-8974	IC12, IC17, IC18, IC19	N7406 HEX. INVERTER BUFFER DRIVERS W/ OPEN COLLECTOR HIGH VOLTAGE OUTPUTS	4
4	5A-8973	IC1 THRU IC4, IC6, IC7, IC13, IC14	N7408 QUADRUPLE 2 INPUT POSITIVE AND GATE	8
5	5A-8975	IC15, IC16	MC14049 INVERTING HEX. BUFFER	2
6	5A-8972	IC5, IC10, IC11	MC6820 PERIPHERAL INTERFACE ADAPTER	3
7	5A-8938	Q1, Q3, Q5, Q7, Q9, Q11, Q13, Q14, Q16, Q18, Q20, Q22, Q24, Q26, Q28, Q30, Q32, Q34, Q36, Q38, Q40, Q42, Q44	2N4401 NPN TRANSISTOR	23
8	5A-8976	Q46, Q48, Q50, Q52, Q54, Q56, Q58, Q60, Q62, Q64, Q66, Q68, Q70, Q72, Q74, Q76	2N5427 DARLINGTON NPN TRANSISTOR	16
9	5A-8977	Q2, Q4, Q6, Q8, Q10, Q12, Q15, Q17, Q19, Q21, Q25, Q27, Q29, Q31, Q33, Q35, Q37, Q39, Q41, Q43, Q45	TIPI22 DARLINGTON NPN POWER TRANSISTOR	22
10	5A-8978	Q53, Q55, Q57, Q59, Q61, Q63, Q65, Q67, Q69, Q71, Q73, Q75, Q77	TIPI42 PNP POWER TRANSISTOR	8
11	5A-8979	Q47, Q49, Q51, Q53, Q55, Q57, Q59, Q61	2N6122 NPN POWER TRANSISTOR	8
12	5A-6258	D1	1N4001 DIODE	1
13	5A-8919	D2 THRU D9	1N4148 DIODE	8
14	5A-9014	S1 THRU S8	2N5060 SCR	8
15	5A-8980	C1 THRU C4, C24, THRU C26, C30, C37, C38, C47, C48	CAPACITOR, CERAMIC, 01 MFD. +80-20% 50 V.	22
16	5A-8995	C16 THRU C23	CAPACITOR, POLYESTER FILM, .1 MFD. 10 V.	7
17	5A-9065	C37 THRU C46, C49 THRU C56	CAPACITOR, CERAMIC, 470 PFD. 20% 50 V.	16
18	5A-8986	C15	CAPACITOR, ELECT., 100 MFD. 10 V.	1
19	5A-8996	C36	CAPACITOR, CERAMIC, 1 MFD. +80-20% 50 V.	1
20	5A-8991	R1 THRU R8, R27, R77 THRU R92, R157 THRU R195	RESISTOR, FC, 4.7 K OHM 10% 1/4 W	62
21	5A-8983	R27	RESISTOR, FC, 3.3 K OHM 10% 1/4 W	1
22	5A-8984	R96, R97, R102, R103, R108, R109, R114, R115, R121, R122, R126, R127, R132, R133, R138, R139, R196 THRU R203	RESISTOR, FC, 1 K OHM 10% 1/4 W	24
23	5A-8992	R7, R10, R13, R16, R19, R22, R29, R32, R35, R36, R41, R44, R47, R50, R53, R56, R59, R62, R65, R68, R71, R74	RESISTOR, FC, 560 OHM 10% 1/4 W	22
24	5A-8993	R8, R11, R14, R17, R20, R23, R30, R33, R36, R39, R42, R45, R48, R51, R54, R57, R60, R63, R66, R69, R72, R75	RESISTOR, FC, 68 OHM 10% 1/4 W	22
25	5A-8997	R9, R12, R15, R18, R21, R24, R25, R31, R34, R37, R40, R43, R46, R49, R52, R55, R58, R61, R64, R67, R70, R73, R76	RESISTOR, FC, 2.7 K OHM 10% 1/4 W	23
26	5A-8817	R26	RESISTOR, FC, 10 K OHM 10% 1/4 W	1
27	5A-8998	R141 THRU R148	RESISTOR, FC, 2.2 K OHM 10% 1/4 W	8
28	5A-8999-1	R149 THRU R156	RESISTOR, FC, 27 OHM 10% 2 W	8
29	5A-9084	R95, R100, R106, R112, R118, R124, R130, R136	RESISTOR, FC, 100 OHM 10% 3 W	8
30	5A-9085	R93, R99, R105, R111, R117, R123, R129, R135	RESISTOR, FC, 1.5 K OHM 10% 1/4 W	8
31	5A-9086	R94, R101, R107, R113, R119, R125, R131, R137	RESISTOR, FC, 6.8 K OHM 10% 1/4 W	8
32	5A-9037	R98, R104, R110, R116, R122, R128, R134, R140	RESISTOR, FIREWOUND, .4 OHM 10% 3 WATT	8
33	5A-8994	Z1	RELAY-4 POLE-5 AMPR CONTACTS 40 OHM COIL 6 V.D.C.	1
34	5A-9066	2P1	8 PIN RECEPTACLE	5
35	5A-9027	2J2 THRU 2J13	9 PIN HEADER	12
36	5A-0534	WBTHRU W16	RESISTOR, FC, 0 OHM, 1/4 W	8

★ R149 THRU R156 MUST BE MOUNTED 1/8" ABOVE SURFACE OF BOARD.

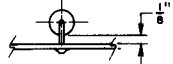

**WILLIAMS ELECTRONICS, INC.**  
 SUBSIDIARY OF XCOR CORPORATION  
 3401 N. CALIFORNIA CHICAGO, ILL. 60618 CORNELIA 7-2240

PART NAME: DRIVER BOARD ASSEMBLY  
 DWN: R. Gay DATE: 8-16-77 APP'D: SCALE: 2:1 PART NO: D-7997



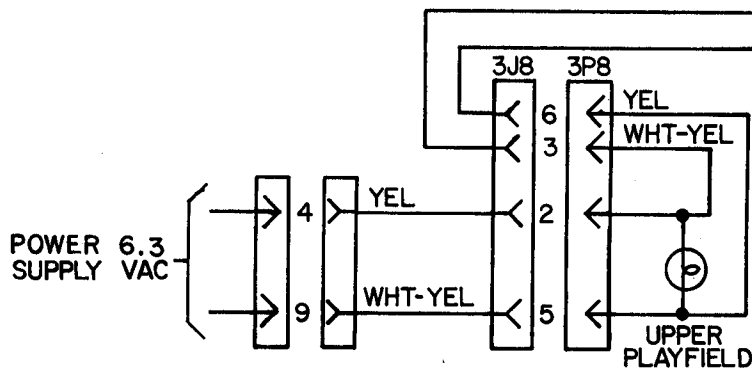
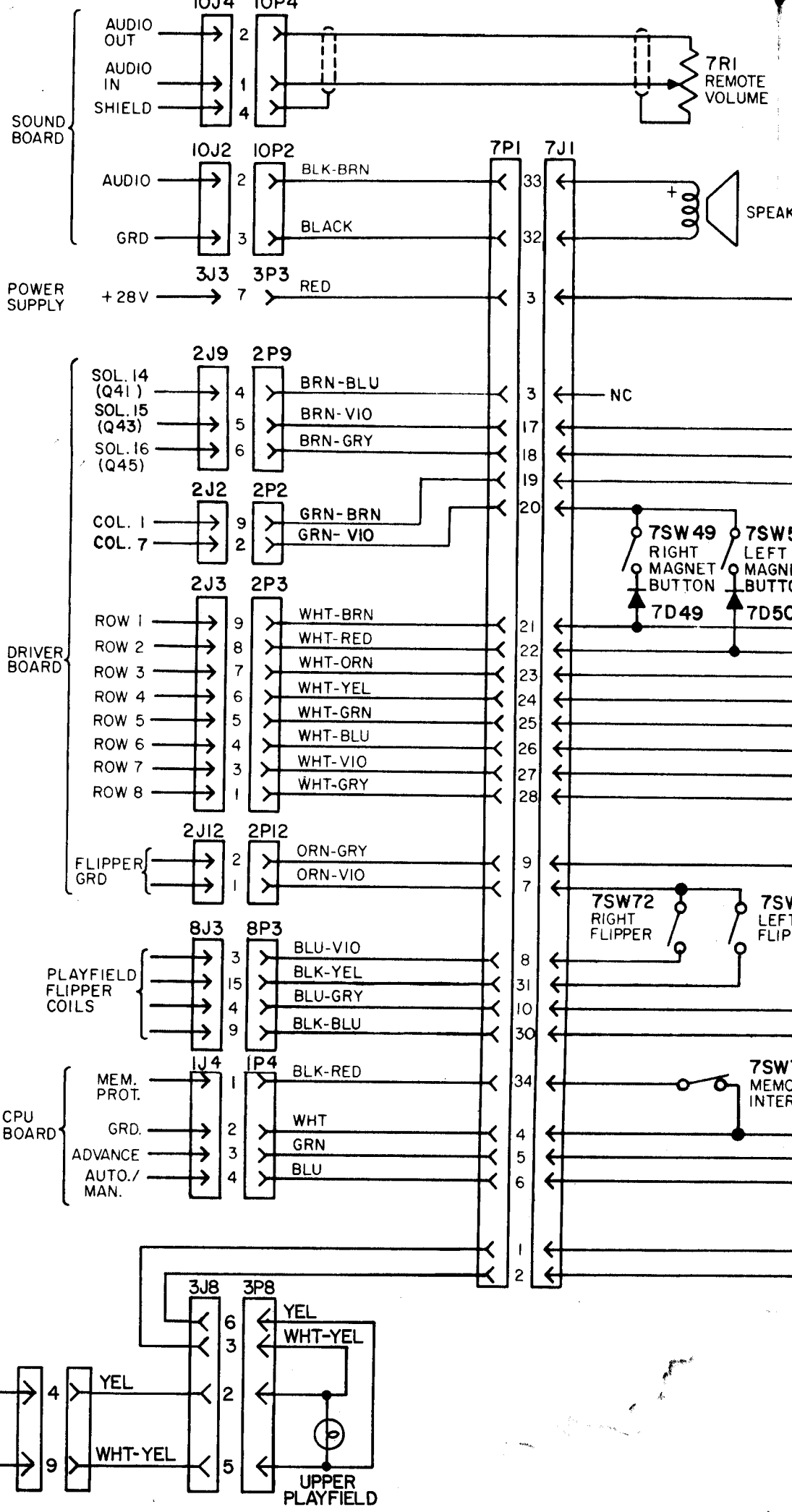



MAKER

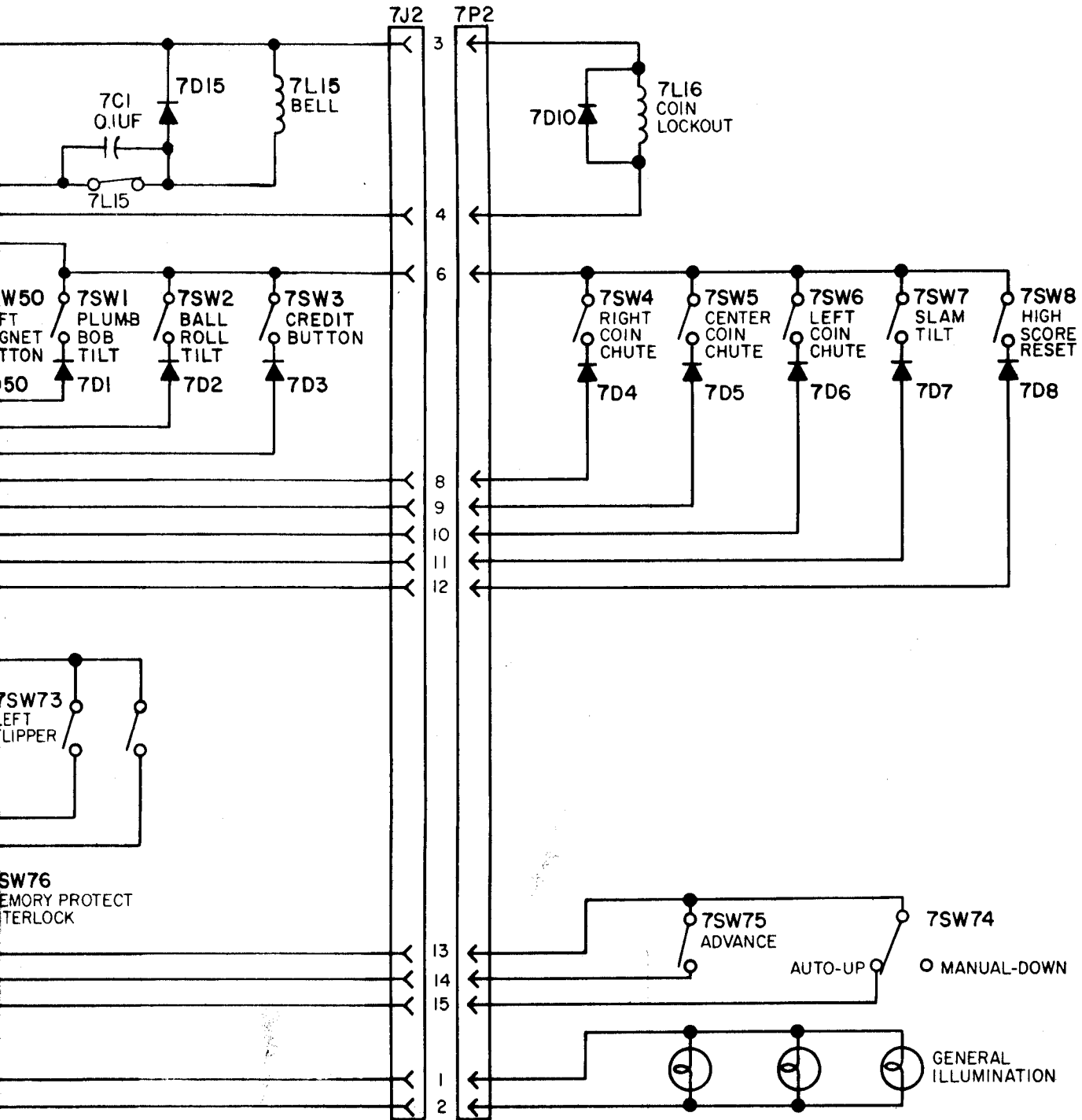

### CABINET WIRING DIAGRAM



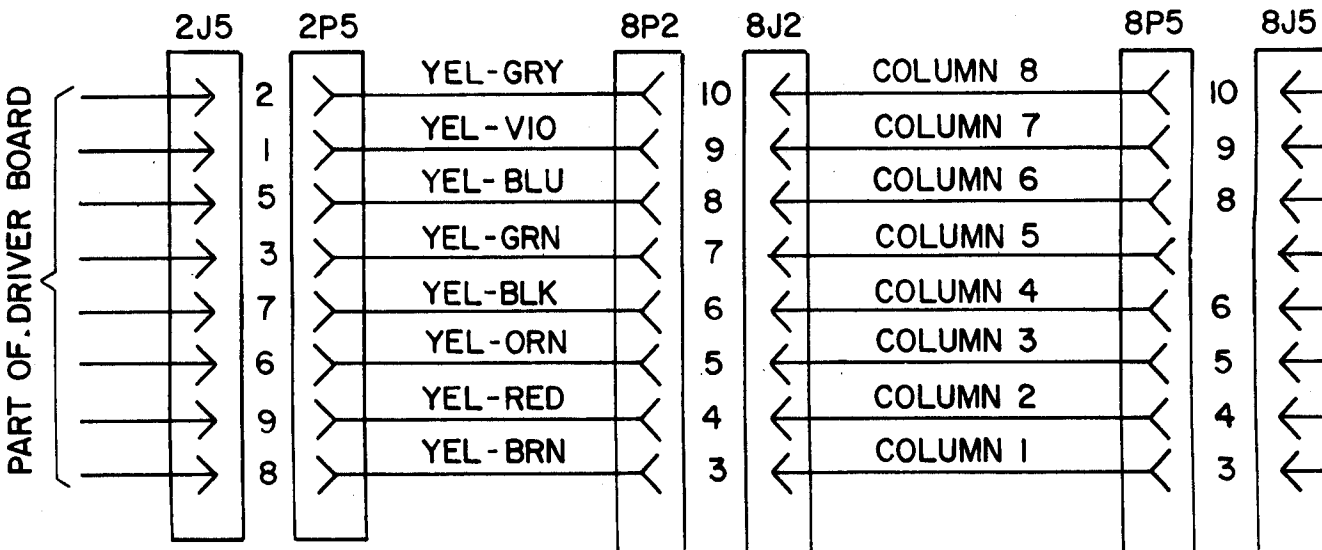

INDICATES MOUNTED ON UPPER PLAYFIELD AND CONNECTIONS ARE NOT ROUTED THROUGH 8P5/8J5.

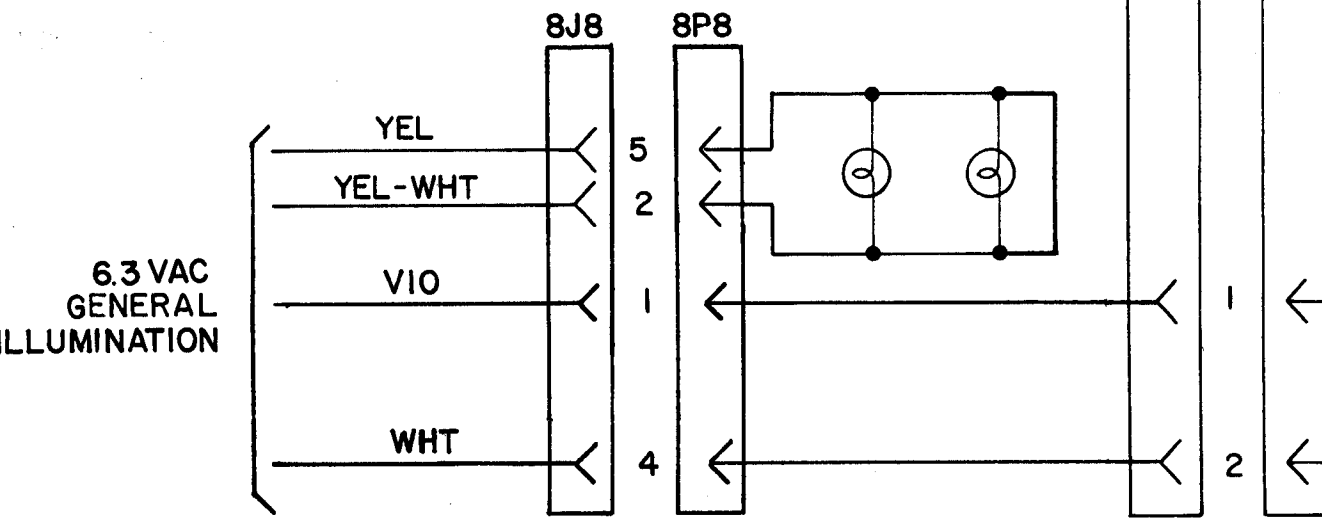
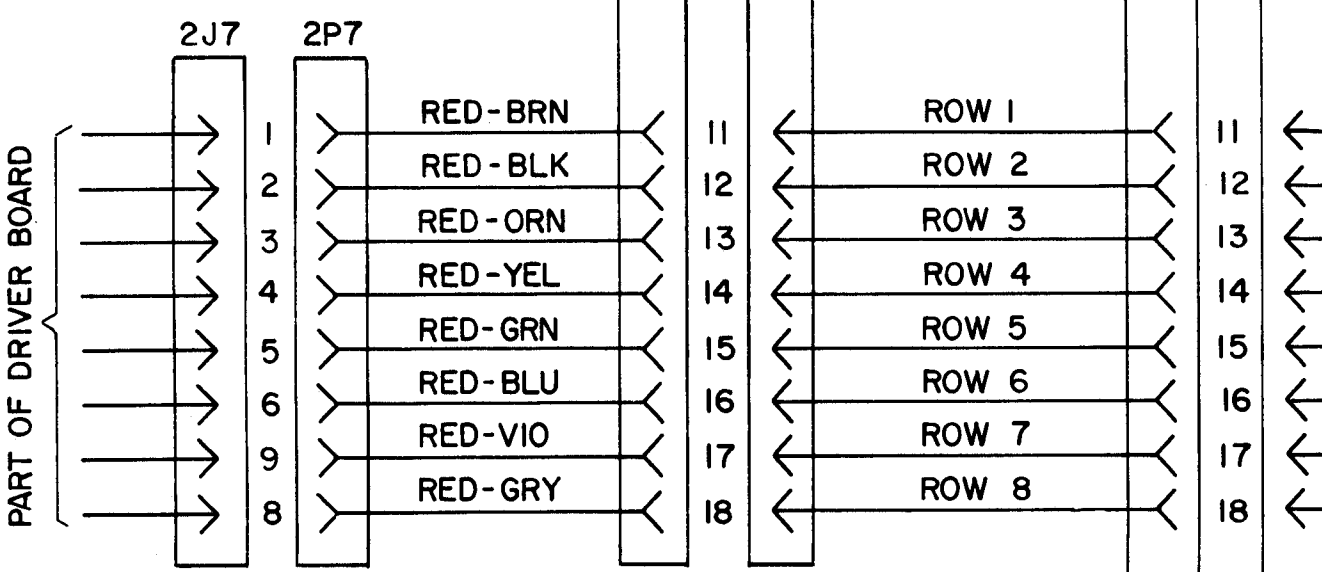



# ANGLE LORD LAMP WIRING DIAGRAM

503

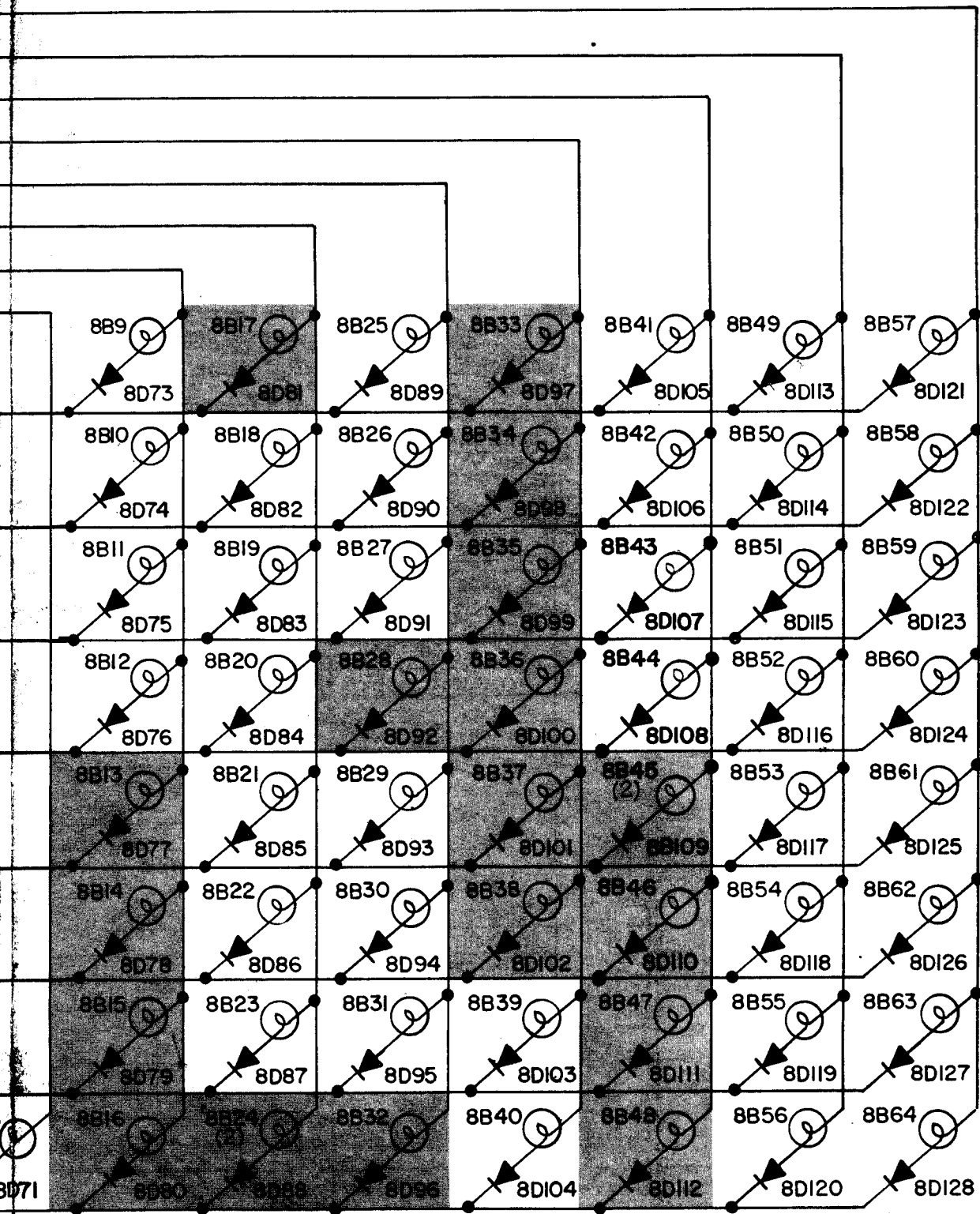

Bulb No.	Function
01	Same Player Shoots Again (B
02	Ball in Play
03	Tilt
04	Game Over
05	Match
06	High score to date
07	Multi-Ball Timer
08	Right magnet Lamp #1 (Bottom)
09	Right magnet Lamp #2
10	Right magnet Lamp #3
11	Right magnet Lamp #4
12	Right magnet Lamp #5 (top)
13	"L"
14	"O"
15	"R"
16	"D"
17	#1 Target
18	#2 Target
19	#3 Target
20	#4 Rollover
21	#5 Rollover
22	Left Drain Shield
23	Right Drain Shield
24	Mini-field Illumination (X2)
25	Right 3-Bank
26	2X Scoring
27	Keep Shooting (Playfield)
28	Mini-field Special
29	Left 3 Bank
30	Loop Spots Letter
31	Loop Spots X Value
32	Mini-field Illumination
33	5-Bank #1 Arrow (Left)
34	5-Bank #2 Arrow
35	5-Bank #3 Arrow
36	5-Bank #4 Arrow
37	5-Bank #5 Arrow (Right)
38	Mini-field Illumination
39	Left magnet #1 (Bottom)
40	Left magnet #2
41	Left Magnet #3
42	Left Magnet #4
43	Left Magnet #5 (Top)
44	Extra Kick When Lit
45	Lock Lamps (X2)
46	Double-Trouble Lamp
47	Mini-field Illumination
48	Mini-field Illumination
49	"1" Bonus
50	"2" Bonus
51	"3" Bonus
52	"4" Bonus
53	"5" Bonus
54	"6" Bonus
55	"7" Bonus
56	"8" Bonus
57	"9" Bonus
58	"10" Bonus
59	"20" Bonus
60	"30" Bonus
61	2X
62	3X
63	5X
64	10X

GENERAL  
ILLUMINATION



SWITCH MATRIX INPUTS 1-8

SWITCH MATRIX DRIVES 1-8

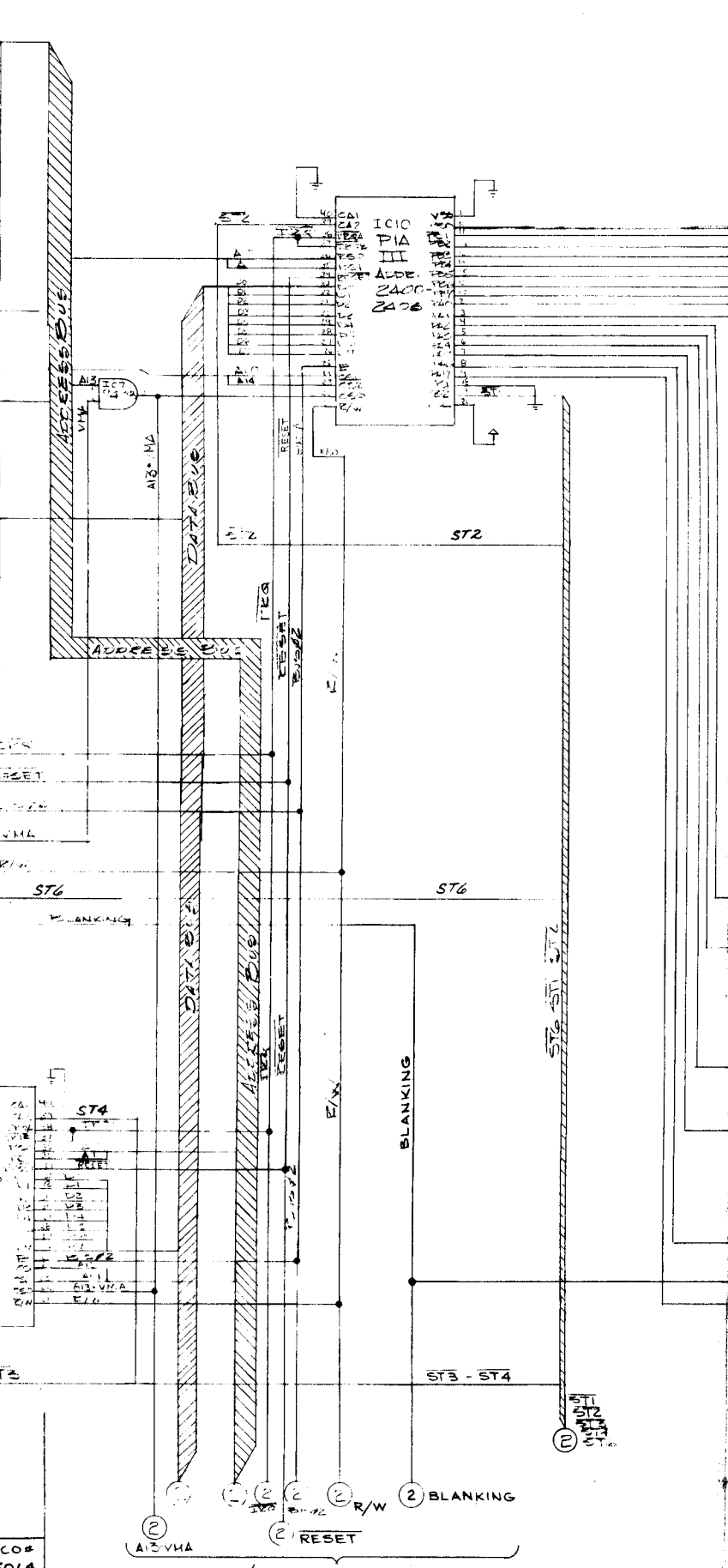
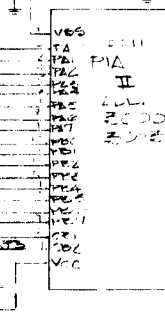
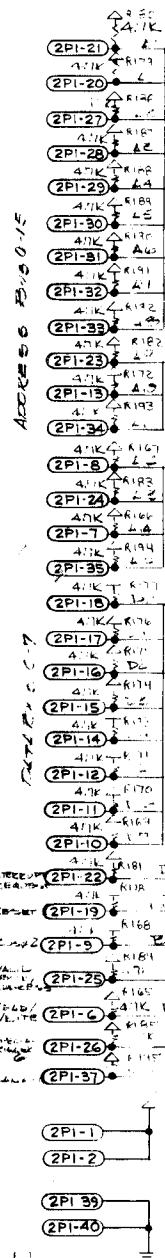
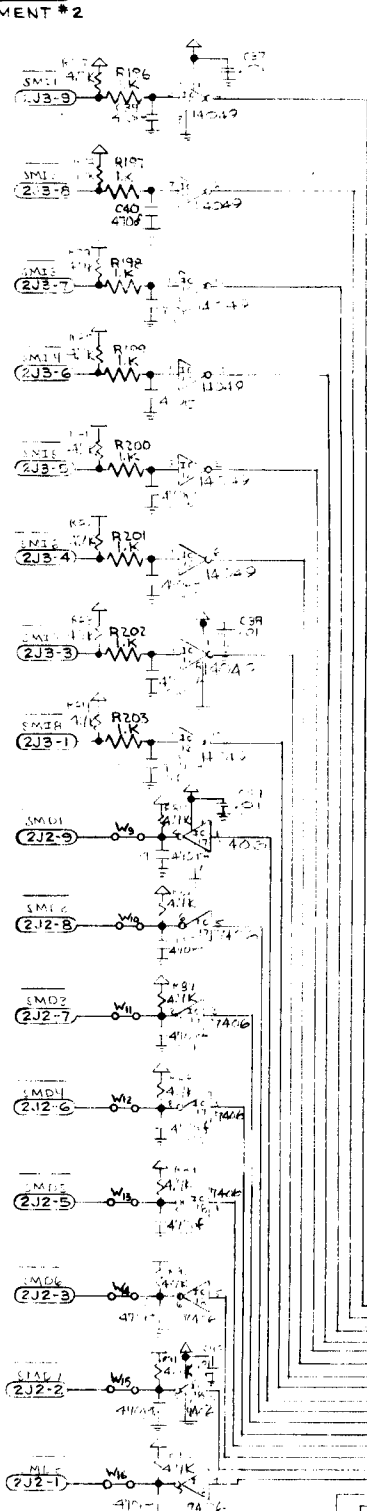

D	10-4-78	A 204 THRU P 211, 3/2/4 WAS 1K Ω	ECO # 4624	
C	10-28-77	2PI'S WAS P6, 2J2'S WAS A5, 2J3'S WAS B5, 2J4'S WAS C5, 2J5'S WAS D5, 2J6'S WAS E5, 2J7'S WAS F5, & ADDED CIR-LETS TO ALL 24G122 & TIPAZ TRANSISTOR & T/F FROM SHEET 2	RGH	
B	8-25-77	DELETED +5V LEAD & ADDED VOLT LAMP Vcc LEAD TO R93-R95, R99-R101, R106-R107, R111-R112, R117-R119, R123-R125, R129-R131 & R135-R137	RGH	
A	8-16-77	REDUCE POWER SUPPLY CURRENT	DLP	
F		R196 THRU R 203 WAS ECO # W1 THRU W6 (11-17-80) 5064		
E		W1 THRU W6 WAS ECO # R196 THRU R 211 5013 TAJ/TM		

TO/FROM SHEET 2  
 (2) BLANKING  
 (2) R/W  
 (2) RESET  
 (2) A13-VHA

ST11-12



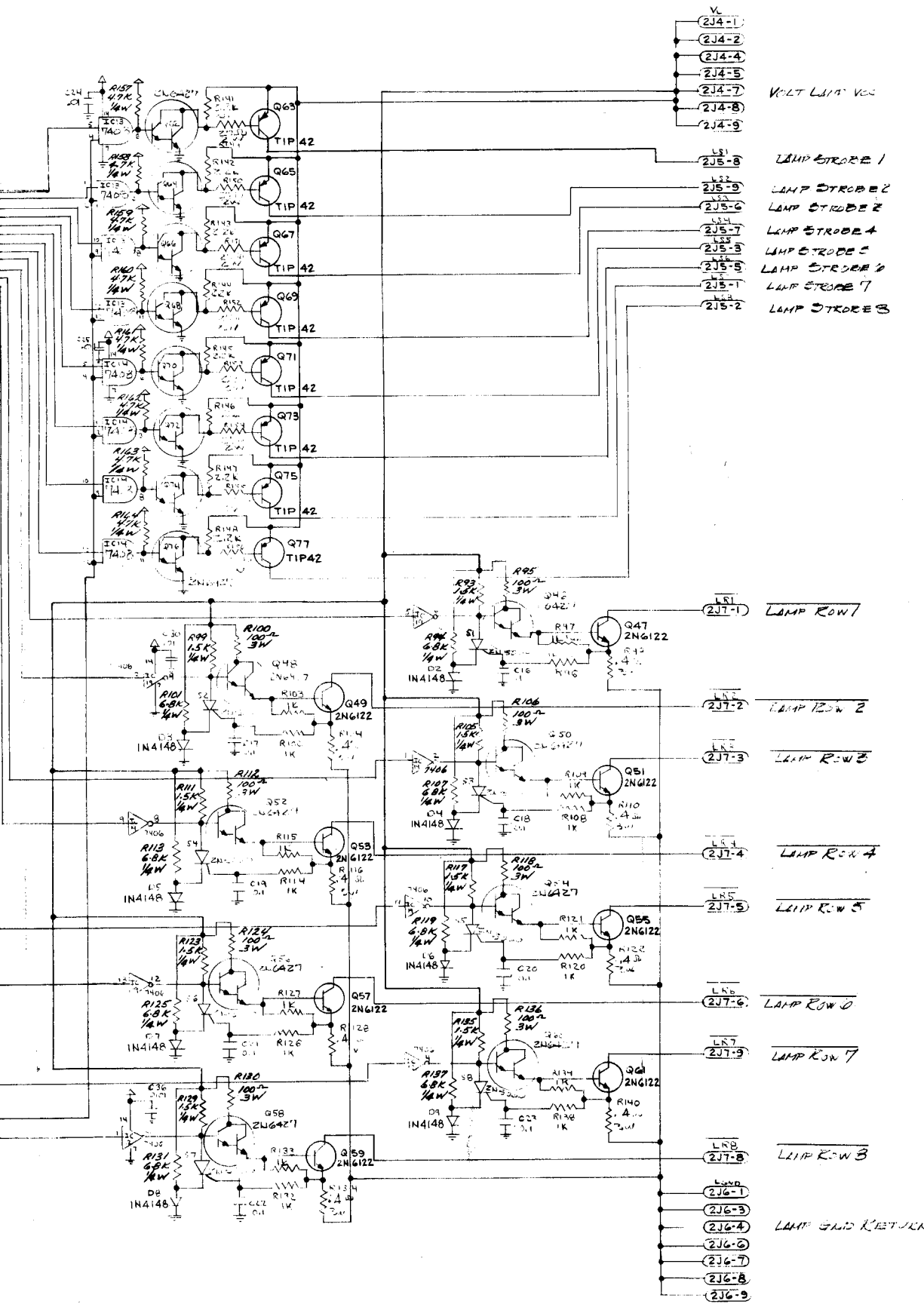

- 2J4-1
- 2J4-2
- 2J4-4
- 2J4-5
- 2J4-7
- 2J4-8
- 2J4-9
- VOLT LAMP VCC
- 2J5-3 LAMP STROBE 1
- 2J5-5 LAMP STROBE 2
- 2J5-6 LAMP STROBE 3
- 2J5-7 LAMP STROBE 4
- 2J5-8 LAMP STROBE 5
- 2J5-9 LAMP STROBE 6
- 2J5-T LAMP STROBE 7
- 2J5-2 LAMP STROBE 8

- 2J7-1 LAMP ROW 1
- 2J7-2 LAMP ROW 2
- 2J7-3 LAMP ROW 3
- 2J7-4 LAMP ROW 4
- 2J7-5 LAMP ROW 5
- 2J7-6 LAMP ROW 6
- 2J7-7 LAMP ROW 7
- 2J7-8 LAMP ROW 8
- 2J6-1
- 2J6-3
- 2J6-4 LAMP GRID RETURN
- 2J6-6
- 2J6-7
- 2J6-8
- 2J6-9

TOLERANCES		WILLIAMS ELECTRONIC MFG. CORP.		
UNLESS OTHERWISE SPECIFIED:		SUBSIDIARY OF THE RESURGENT CORP.		
FRACTIONS	± 1/64	3401 N. CALIFORNIA		CORNELIA 7-8840
DECIMALS	± .008	CHICAGO 18, ILL.		
HOLES	± .008	NAME SCHEMATIC, DRIVER BOARD		
ANGULAR	± 1/8°	MATERIAL	HEAT TREATMENT	FINISH
		W/E	7777	APPD. SCALE
				16-7997

Driver Board Logic Diagram  
(Sheet 1 of 2) 11/12



SOLENOID 1 DRIVE

SOLENOID 2 DRIVE

SOLENOID 3 DRIVE

SOLENOID 4 DRIVE

SOLENOID 5 DRIVE

SOLENOID 6 DRIVE

SOLENOID 7 DRIVE

SOLENOID 8 DRIVE

SOLENOID 9 DRIVE

SOLENOID 10 DRIVE

SOLENOID 11 DRIVE

SOLENOID 12 DRIVE

SOLENOID 13 DRIVE

SOLENOID 14 DRIVE

SOLENOID 15 DRIVE

SOLENOID 16 DRIVE

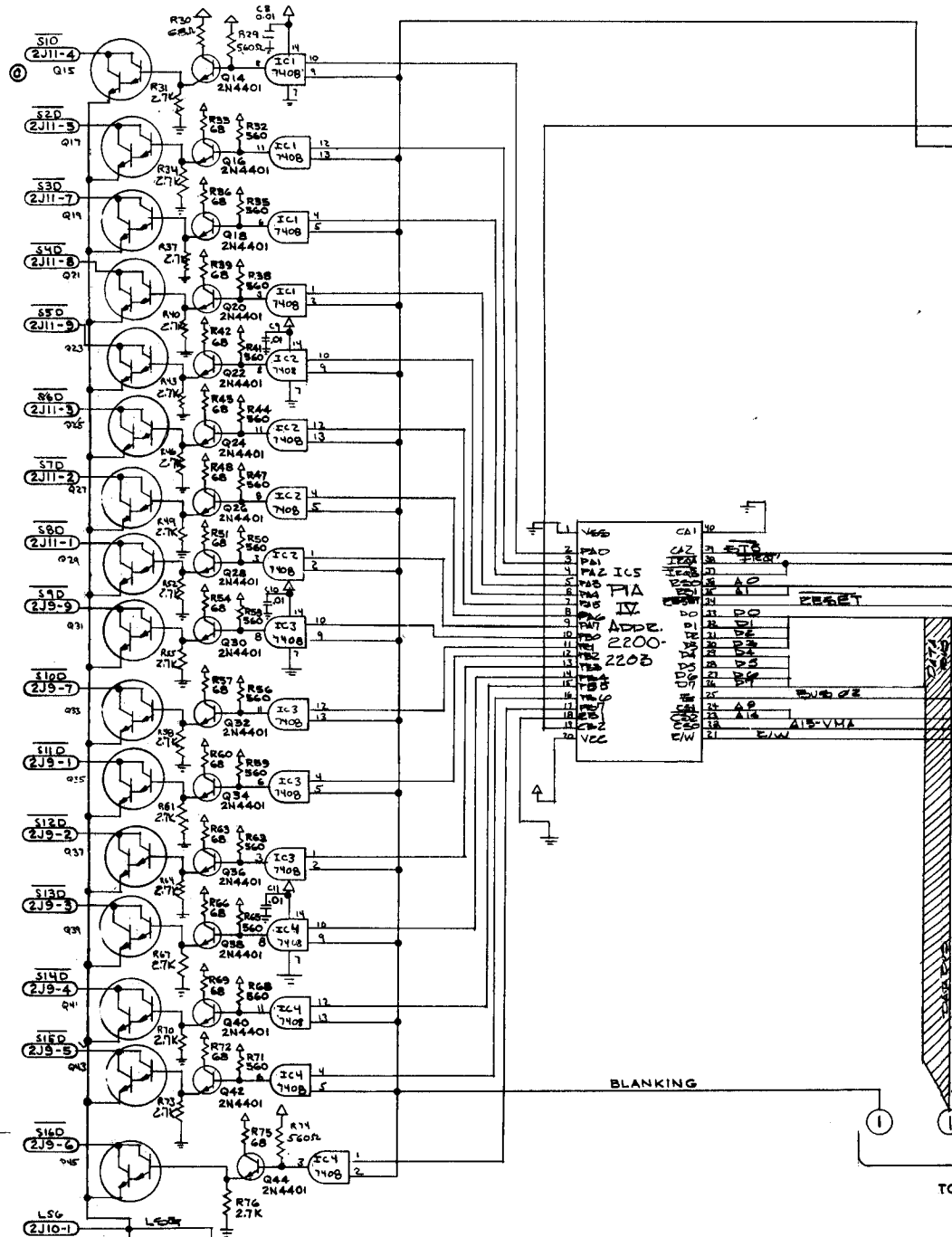

LAMP & SOLENOID GROUND

LAMP & SOLENOID GND.

C	CHANGE TIP 120 TO VENDOR SELECTED DARLINGTON	ECO. 4889
B	2J8'S WAS G'S, 2J9'S WAS H'S, 2J10'S WAS J'S, 2J11 WAS K'S, 2J12 WAS L'S, 2J13'S WAS M'S & ADDED 17 TO FROM SHEET 1 & CIRCLES TO ALL 2N4401 TRANSISTORS	R. Giff 10-28-77
A	REVISION "A"	
REVISION LETTER	REVISION	BY

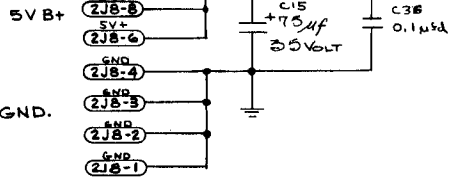

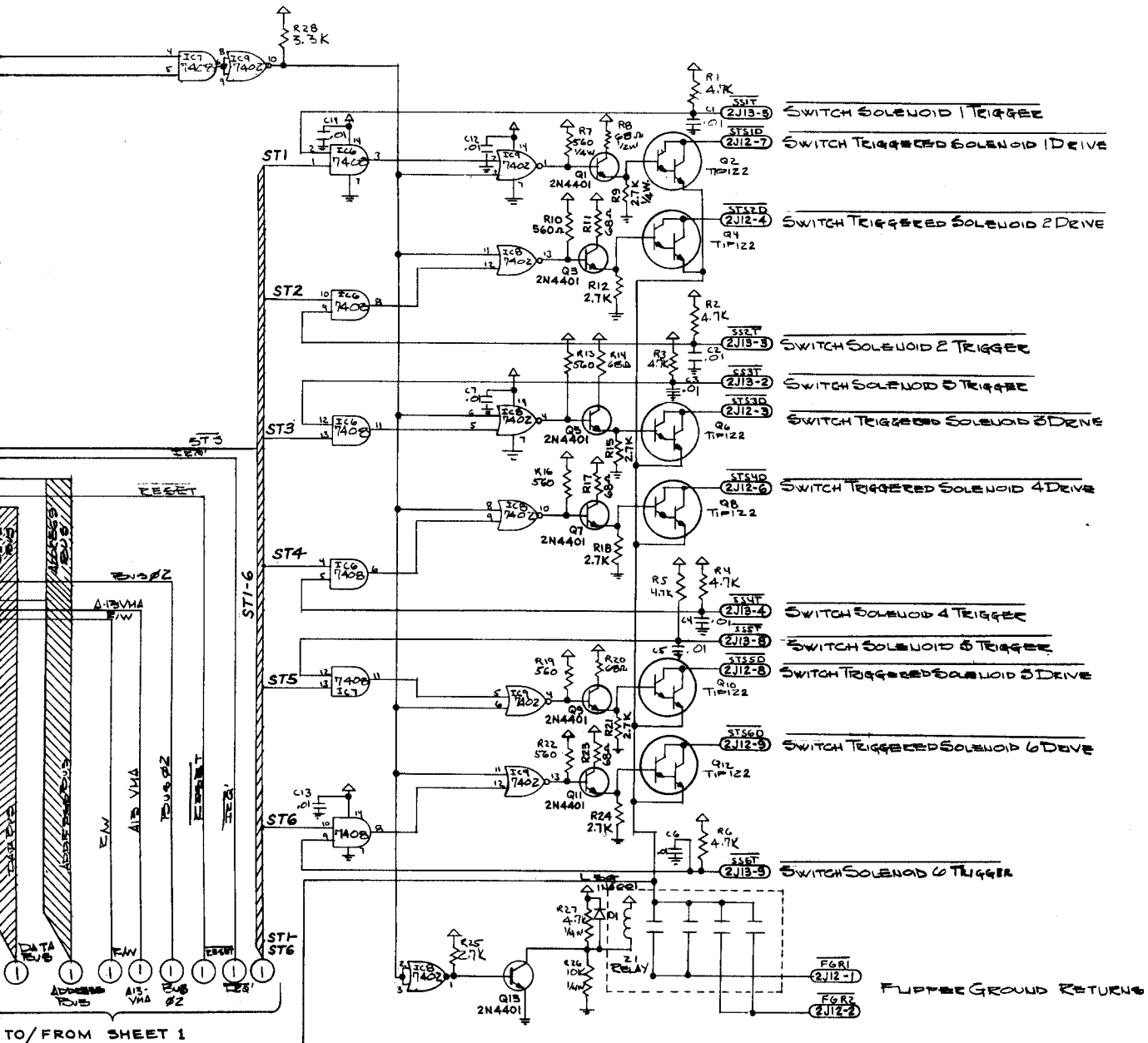

TOLERANCES UNLESS OTHERWISE SPECIFIED		WILLIAMS ELECTRONIC MFG. CORP. SUBSIDIARY OF THE BUSHING CORP.	
FRACTIONS ± 1/64	DECIMALS ± .008	3401 N. CALIFORNIA	CHICAGO 18, ILL. CORNELIA 7-2240
HOLES + .008	ANGULAR ± 1/8°	NAME SCHEMATIC, DRIVER BOARD	
MATERIAL		HEAT TREATMENT FINISH	
DATE 1-3-77	APP'D.	SCALE	16D-7997

SHEET 2 OF 2

Driver Board Logic Diagram  
(Sheet 2 of 2) 13



# BILL OF MATERIAL

ITEM	PART NO.	DESCRIPTION	QTY
EA	1	BASE PCB BOARD	1
EA	2	RESISTOR 2.2K 1/4W 5% 100	1
EA	3	RESISTOR 10K 1/4W 5% 100	1
EA	4	RESISTOR 100K 1/4W 5% 100	1
EA	5	RESISTOR 100K 1/4W 5% 100	1
EA	6	RESISTOR 100K 1/4W 5% 100	1
EA	7	RESISTOR 100K 1/4W 5% 100	1
EA	8	RESISTOR 100K 1/4W 5% 100	1
EA	9	RESISTOR 100K 1/4W 5% 100	1
EA	10	RESISTOR 100K 1/4W 5% 100	1
EA	11	RESISTOR 100K 1/4W 5% 100	1
EA	12	RESISTOR 100K 1/4W 5% 100	1
EA	13	RESISTOR 100K 1/4W 5% 100	1
EA	14	RESISTOR 100K 1/4W 5% 100	1
EA	15	RESISTOR 100K 1/4W 5% 100	1
EA	16	RESISTOR 100K 1/4W 5% 100	1
EA	17	RESISTOR 100K 1/4W 5% 100	1
EA	18	RESISTOR 100K 1/4W 5% 100	1
EA	19	RESISTOR 100K 1/4W 5% 100	1
EA	20	RESISTOR 100K 1/4W 5% 100	1
EA	21	RESISTOR 100K 1/4W 5% 100	1
EA	22	RESISTOR 100K 1/4W 5% 100	1
EA	23	RESISTOR 100K 1/4W 5% 100	1
EA	24	RESISTOR 100K 1/4W 5% 100	1
EA	25	RESISTOR 100K 1/4W 5% 100	1
EA	26	RESISTOR 100K 1/4W 5% 100	1
EA	27	RESISTOR 100K 1/4W 5% 100	1
EA	28	RESISTOR 100K 1/4W 5% 100	1
EA	29	RESISTOR 100K 1/4W 5% 100	1
EA	30	RESISTOR 100K 1/4W 5% 100	1
EA	31	RESISTOR 100K 1/4W 5% 100	1
EA	32	RESISTOR 100K 1/4W 5% 100	1
EA	33	RESISTOR 100K 1/4W 5% 100	1
EA	34	RESISTOR 100K 1/4W 5% 100	1
EA	35	RESISTOR 100K 1/4W 5% 100	1
EA	36	RESISTOR 100K 1/4W 5% 100	1
EA	37	RESISTOR 100K 1/4W 5% 100	1
EA	38	RESISTOR 100K 1/4W 5% 100	1
EA	39	RESISTOR 100K 1/4W 5% 100	1
EA	40	RESISTOR 100K 1/4W 5% 100	1
EA	41	RESISTOR 100K 1/4W 5% 100	1
EA	42	RESISTOR 100K 1/4W 5% 100	1
EA	43	RESISTOR 100K 1/4W 5% 100	1
EA	44	RESISTOR 100K 1/4W 5% 100	1
EA	45	RESISTOR 100K 1/4W 5% 100	1
EA	46	RESISTOR 100K 1/4W 5% 100	1
EA	47	RESISTOR 100K 1/4W 5% 100	1
EA	48	RESISTOR 100K 1/4W 5% 100	1
EA	49	RESISTOR 100K 1/4W 5% 100	1
EA	50	RESISTOR 100K 1/4W 5% 100	1
EA	51	RESISTOR 100K 1/4W 5% 100	1
EA	52	RESISTOR 100K 1/4W 5% 100	1
EA	53	RESISTOR 100K 1/4W 5% 100	1
EA	54	RESISTOR 100K 1/4W 5% 100	1
EA	55	RESISTOR 100K 1/4W 5% 100	1
EA	56	RESISTOR 100K 1/4W 5% 100	1
EA	57	RESISTOR 100K 1/4W 5% 100	1
EA	58	RESISTOR 100K 1/4W 5% 100	1
EA	59	RESISTOR 100K 1/4W 5% 100	1
EA	60	RESISTOR 100K 1/4W 5% 100	1
EA	61	RESISTOR 100K 1/4W 5% 100	1
EA	62	RESISTOR 100K 1/4W 5% 100	1
EA	63	RESISTOR 100K 1/4W 5% 100	1
EA	64	RESISTOR 100K 1/4W 5% 100	1
EA	65	RESISTOR 100K 1/4W 5% 100	1
EA	66	RESISTOR 100K 1/4W 5% 100	1
EA	67	RESISTOR 100K 1/4W 5% 100	1
EA	68	RESISTOR 100K 1/4W 5% 100	1
EA	69	RESISTOR 100K 1/4W 5% 100	1
EA	70	RESISTOR 100K 1/4W 5% 100	1
EA	71	RESISTOR 100K 1/4W 5% 100	1
EA	72	RESISTOR 100K 1/4W 5% 100	1
EA	73	RESISTOR 100K 1/4W 5% 100	1
EA	74	RESISTOR 100K 1/4W 5% 100	1
EA	75	RESISTOR 100K 1/4W 5% 100	1
EA	76	RESISTOR 100K 1/4W 5% 100	1
EA	77	RESISTOR 100K 1/4W 5% 100	1
EA	78	RESISTOR 100K 1/4W 5% 100	1
EA	79	RESISTOR 100K 1/4W 5% 100	1
EA	80	RESISTOR 100K 1/4W 5% 100	1
EA	81	RESISTOR 100K 1/4W 5% 100	1
EA	82	RESISTOR 100K 1/4W 5% 100	1
EA	83	RESISTOR 100K 1/4W 5% 100	1
EA	84	RESISTOR 100K 1/4W 5% 100	1
EA	85	RESISTOR 100K 1/4W 5% 100	1
EA	86	RESISTOR 100K 1/4W 5% 100	1
EA	87	RESISTOR 100K 1/4W 5% 100	1
EA	88	RESISTOR 100K 1/4W 5% 100	1
EA	89	RESISTOR 100K 1/4W 5% 100	1
EA	90	RESISTOR 100K 1/4W 5% 100	1
EA	91	RESISTOR 100K 1/4W 5% 100	1
EA	92	RESISTOR 100K 1/4W 5% 100	1
EA	93	RESISTOR 100K 1/4W 5% 100	1
EA	94	RESISTOR 100K 1/4W 5% 100	1
EA	95	RESISTOR 100K 1/4W 5% 100	1
EA	96	RESISTOR 100K 1/4W 5% 100	1
EA	97	RESISTOR 100K 1/4W 5% 100	1
EA	98	RESISTOR 100K 1/4W 5% 100	1
EA	99	RESISTOR 100K 1/4W 5% 100	1
EA	100	RESISTOR 100K 1/4W 5% 100	1

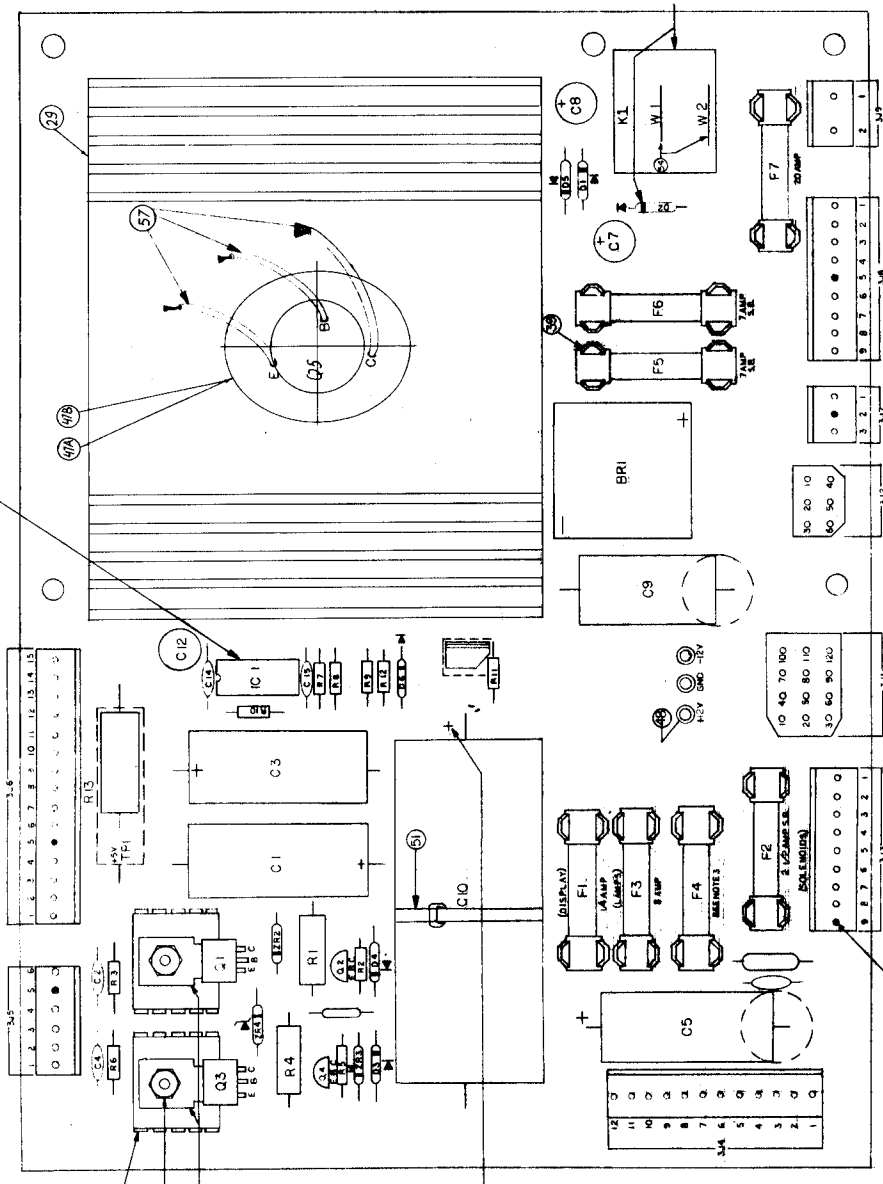

NOTES: HEAT SINK COMPOUND MUST BE APPLIED BETWEEN TRANSISTOR AND HEAT SINK.  
 6. FOR BLACKOUT MANUFACTURE SAMES WITH SAME FEATURE.  
 7. REMOVE JUMPERS (W1 AND W2) AND INSERT RELAYS. (DO NOT LEAVE JUMPERS).  
 8. SOLDER JUMPERS (W1 AND W2) AND INSERT RELAYS. (DO NOT LEAVE JUMPERS).  
 9. CAPACITORS (C1-C10) MUST BE PLACED IN THE POSITION OF PARALLELITY.  
 10. CAPACITORS (C1-C10) MUST BE PLACED IN THE POSITION OF PARALLELITY.  
 11. CAPACITORS (C1-C10) MUST BE PLACED IN THE POSITION OF PARALLELITY.  
 12. CAPACITORS (C1-C10) MUST BE PLACED IN THE POSITION OF PARALLELITY.

REVISION	REVISION NO.	DESCRIPTION
1	0	PCB
2	0	SCHEMATIC
3	0	PCB
4	0	PL

REVISION	REVISION NO.	DESCRIPTION
A	1	CHANGE
A	2	CHANGE
A	3	CHANGE
A	4	CHANGE
A	5	CHANGE
A	6	CHANGE
A	7	CHANGE
A	8	CHANGE
A	9	CHANGE
A	10	CHANGE
A	11	CHANGE
A	12	CHANGE
A	13	CHANGE
A	14	CHANGE
A	15	CHANGE
A	16	CHANGE
A	17	CHANGE
A	18	CHANGE
A	19	CHANGE
A	20	CHANGE
A	21	CHANGE
A	22	CHANGE
A	23	CHANGE
A	24	CHANGE
A	25	CHANGE
A	26	CHANGE
A	27	CHANGE
A	28	CHANGE
A	29	CHANGE
A	30	CHANGE
A	31	CHANGE
A	32	CHANGE
A	33	CHANGE
A	34	CHANGE
A	35	CHANGE
A	36	CHANGE
A	37	CHANGE
A	38	CHANGE
A	39	CHANGE
A	40	CHANGE
A	41	CHANGE
A	42	CHANGE
A	43	CHANGE
A	44	CHANGE
A	45	CHANGE
A	46	CHANGE
A	47	CHANGE
A	48	CHANGE
A	49	CHANGE
A	50	CHANGE
A	51	CHANGE
A	52	CHANGE
A	53	CHANGE
A	54	CHANGE
A	55	CHANGE
A	56	CHANGE
A	57	CHANGE
A	58	CHANGE
A	59	CHANGE
A	60	CHANGE
A	61	CHANGE
A	62	CHANGE
A	63	CHANGE
A	64	CHANGE
A	65	CHANGE
A	66	CHANGE
A	67	CHANGE
A	68	CHANGE
A	69	CHANGE
A	70	CHANGE
A	71	CHANGE
A	72	CHANGE
A	73	CHANGE
A	74	CHANGE
A	75	CHANGE
A	76	CHANGE
A	77	CHANGE
A	78	CHANGE
A	79	CHANGE
A	80	CHANGE
A	81	CHANGE
A	82	CHANGE
A	83	CHANGE
A	84	CHANGE
A	85	CHANGE
A	86	CHANGE
A	87	CHANGE
A	88	CHANGE
A	89	CHANGE
A	90	CHANGE
A	91	CHANGE
A	92	CHANGE
A	93	CHANGE
A	94	CHANGE
A	95	CHANGE
A	96	CHANGE
A	97	CHANGE
A	98	CHANGE
A	99	CHANGE
A	100	CHANGE





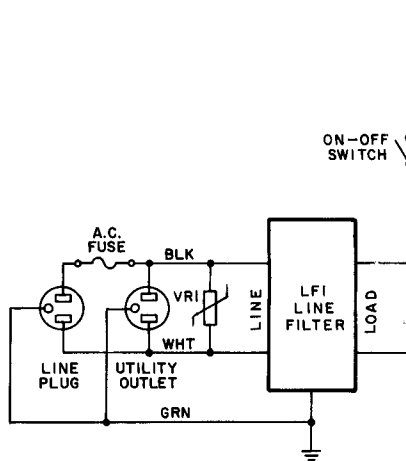

NOTE 3

NOTE 4

NOTES:

1. FOR 105 OR 117V.A.C., 7.5A FUSE & 130V. VARISTOR #5A-9044 ARE USED.
2. FOR 210 OR 235V.A.C., 4A FUSE & 275V. VARISTOR #5A-9063 ARE USED.
3. JUMPER WIRES ON 6P1 SHOWN WITH SOLID LINES ARE CONNECTED FOR 117V.A.C. OPERATION. ONLY THE ONE SHOWN WITH A DASHED LINE IS CONNECTED FOR 220V.A.C. OPERATION.
4. FOR LOW-LINE CONDITIONS (105 OR 210V.A.C.) MOVE BLK-WHT WIRE FROM 6T1-4 TO 6T1-3) & MOVE 2 WHT-RED WIRES FROM 6T1-8 TO 6T1-7.

POWER WIRING

7T1

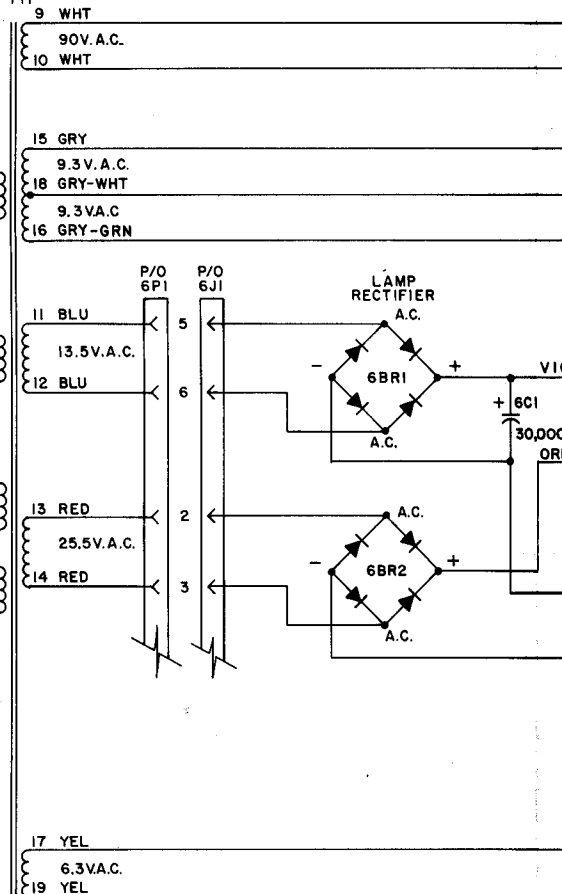

DRIVER BOARD S

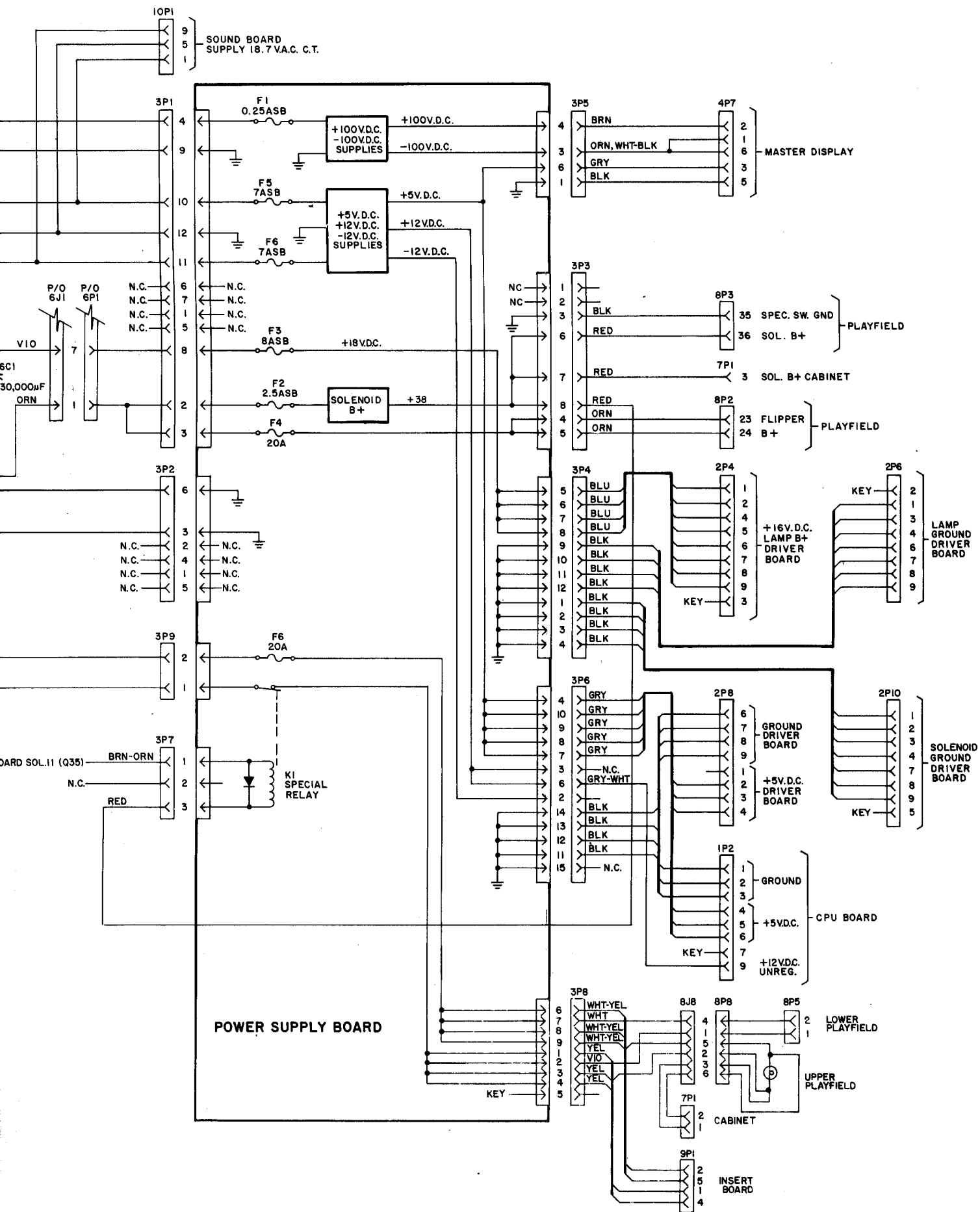

Power Wiring Diagram 15



ITEM NO.	PART NO.	PART DESIGNATION	DESCRIPTION
58			6-32 x 3/8" BINDER
59			6-32 HEX NUT
60		W1, W2, W6, W7, W9, W10, W15	WIRE JUMPER 22 AWG
61	FA-9248	TP1 THR TPA	TERMINAL # 30
62	5A-9363	R11	RESISTOR, FF, 5% 1/4 WATT
64	5A-9362	SR1	RESISTOR, 47 OHMS, 10 PIN SIP
65	3A-7520-1		TIE WRAP

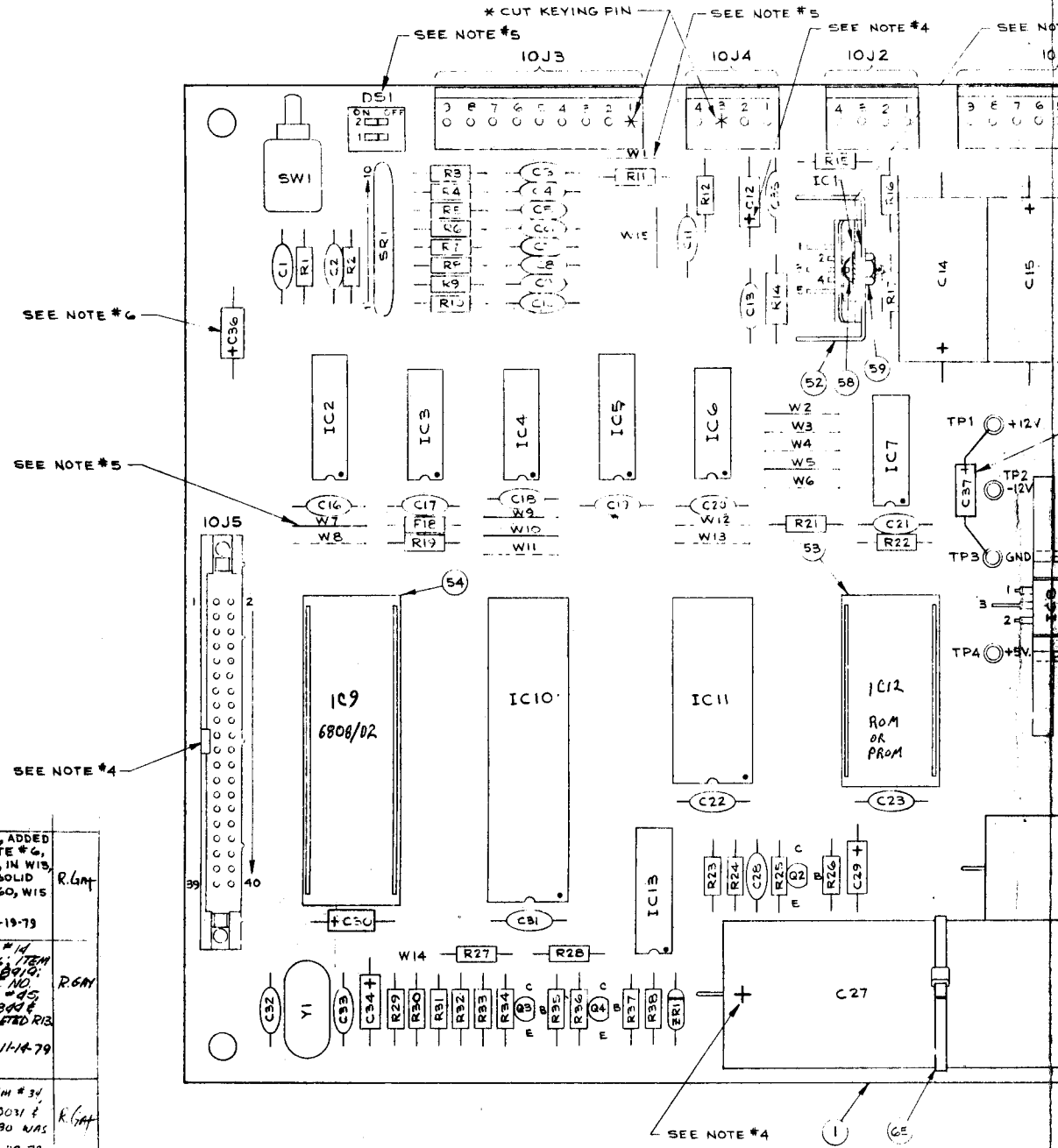

REVISION	REVISION	BY
E	REVISED NOTES, ADDED ITEM #45 & NOTE #6, RELOCATED W15, W16, DASH LINE WAS SOLID LINE & ITEM #60, W15 WAS W16 E.C.O. 11-19-79	R.G.M.
D	DELETED ITEM #14, PT. NO. 5A-9306, ITEM #16, PT. NO. 5A-8919, ITEM #25, PT. NO. 5A-9314, ITEM #45, PT. NO. 5A-9300 & IN ITEM #21, DELETED R12, QTY. WAS 6 E.C.O. 4764 11-14-79	R.G.M.
C	ADDED C36, ITEM #34, PT. NO. WAS 5A-9301 & QTY. WAS 1, & C30 WAS OF MFD. E.C.O. 4760 10-29-79	R.G.M.
B	DELETED ITEM #62, ADDED ITEM #10, QTY. WAS 7, ITEM #11, QTY. WAS 7, ITEM #12, QTY. WAS 1, ITEM #62, QTY. WAS 1, ITEM #62, QTY. WAS 1	R.G.M.
A		R.G.M.

DESCRIPTION	REQ'D. NO.	ITEM NO.	PART NO.	PART DESIGNATION	DESCRIPTION	REQ'D. NO.
SCREW HEAD SCREW	3	48	5A-6314	F1, F2	4 AMP SLOW BLOW FUSE	2
INSULATION	3	49	5A-9178		FUSE HOLDER	4
22 GAUGE INSULATION	7	50	5A-9172		HEAT SINK THERMALLOY #6072B	1
502-1	4	51	5A-9173		HEAT SINK THERMALLOY #6071B	1
5.6 K OHM	1	52	5A-9199		HEAT SINK THERMALLOY #6030	1
1.7 K OHM	1	53	5A-9004		24 PIN SOCKET	1
	1	54	5A-8985		40 PIN SOCKET	1
	1	55	5A-9027	10J1, 10J3	9 PIN MALE CONNECTOR	2
	1	56	5A-9028	10J2, 10J4	4 PIN MALE CONNECTOR	2
	1	57	5A-9349	10J5	40 PIN RIBBON HEADER	1

BILL OF MATERIAL				
ITEM NO.	PART NO.	PART DESIGNATION	DESCRIPTION	REQ'D. NO.
1	IC-2001-146-3		BARE P.C. BOARD	1
2	5A-9156	IC1	TDA2002 V AUDIO AMPLIFIER	1
3	5A-9012	IC2	7442 BCD-DEC DECODER	1
4	5A-9073	IC3	7400 QUAD 2 INPUT NAND	1
5	5A-8973	IC4	7408 QUAD 2 INP. AND GATE	1
6	5A-9153	IC5	4050 BUFFER	1
7	5A-9154	IC6	4068 8 INPUT NAND GATE	1
8	5A-8971	IC7	14069 HEX INVERTER	1
9	5A-9157	IC8	7805 5 VOLT REG. W/TO220 CASE	1
10	5A-8972	IC10	6821 P.I.A.	1
11	5A-9003	IC11	6810 RAM	1
12	5A-9152	IC13	1408 D/A CONVERTER	1
13	5C-8938	Q2, Q3, Q4	2N4401 NPN TRANSISTOR	3
14				
15	5A-9018	ZK1	1N5996 6.8V. ZENER DIODE	1
16				
17	5A-9158 OR 5A-9357	BR1	MDA 200/3N253 BRIDGE RECTIFIER	1
18	5A-9020	Y1	3.58 MHZ CRYSTAL	1
19	5B-8991	R1, R19, R21, R22, R27, R30, R31, R32	RESISTOR, FC, 4.7K OHM 5% 1/4 WATT	9
20	5B-9036	R2 THRU R10	RESISTOR, FC, 100 OHM 10% 1/4 WATT	9
21	5A-8984	R12, R28, R36, R38	RESISTOR, FC, 1K OHM 10% 1/4 WATT	5
22	5A-9181	R14	RESISTOR, FC, 1 OHM 10% 1/2 WATT	1
23	5A-9161	R16	RESISTOR, FC, 2.2 OHM 10% 1/4 WATT	1
24	5A-9361	R17	RESISTOR, FC, 220 OHM 10% 1/2 WATT	1
25				
26	5B-8985	R23, R24, R26	RESISTOR, FC, 3.3K OHM 10% 1/4 WATT	3
27	5A-9179	R25	RESISTOR, FC, 3.3M OHM 10% 1/4 WATT	1
28	5A-9359	R29	RESISTOR, FC, 47K OHM 5% 1/4 WATT	1
29	5B-8817	R33, R35, R37	RESISTOR, FC, 10K OHM 10% 1/4 WATT	3
30	5B-9039	R34	RESISTOR, FC, 10 OHM 10% 1/4 WATT	1
31	5A-8980	C1, C16 THRU C23, C31	CAPACITOR, CERAMIC, .01 MFD. 50 V. ±20%	11
32	5A-9065	C2 THRU C10	CAPACITOR, CERAMIC, 470 PFD. 50 V. ±20%	9
33	5A-9345	C11	CAPACITOR, CERAMIC, .001 MFD. 20% 100 V.	1
34	5A-9345	C12, C30, C36	CAPACITOR, ELECTROLYTIC 1 MFD. 6.3 V. -10/+50%	3
35	5A-8996	C13, C24, C35	CAPACITOR, CERAMIC, .1 MFD. 50 V. ±20%	3
36	5A-9165 OR 5A-9165-1	C14	CAPACITOR, ELECTROLYTIC, 800 MFD. 16 V. OR 1,000 MFD. 15 V. ±20%	1
37	5A-9164 OR 5A-9164-1	C15	CAPACITOR, ELECTROLYTIC, 500 MFD. 15 V. OR 470 MFD. 25 V. ±20%	1
38	5A-8986	C25	CAPACITOR, ELECTROLYTIC, 100 MFD. 10 V. ±20%	1
39	5A-8893	C26	CAPACITOR, ELECTROLYTIC, 1,000 MFD. 25 V. ±20%	1
40	5A-9046	C27	CAPACITOR, ELECTROLYTIC, 12,000 MFD. 16 V. ±20%	1
41	5A-9180	C28	CAPACITOR, CERAMIC, 47 PFD. 1K V. ±20%	1
42	5A-9343	C29	CAPACITOR, ELECTROLYTIC, 10 MFD. 25 V. LOW LEAK ±20%	1
43	5A-9169	C32, C33	CAPACITOR, CERAMIC DISC, 27 PFD. 1K V. ±10%	2
44	5A-9163	C34	CAPACITOR, TANTALUM, 2.2 MFD. 15 V. ±20%	1
45	5A-9031	C37	CAPACITOR, TANTALUM, 1 MFD. 25 V. ±20%	1
46	5A-9024	SW1	MOMENTARY SWITCH SPDT	1
47	5A-9330	DS1	2 STD. DIP SWITCH	1

**NOTES:**

- USE THERMAL COMPOUND BETWEEN IC'S AND HEAT SINK.
- CAUTION: AVOID STATIC DISCHARGE DAMAGE TO MOS LOGIC.
- SYMBOLS SHOWN ON COMPONENTS ARE FOR REFERENCE ONLY. DO NOT SCREEN OR STAMP.
- OBSERVE INDEX MARK OF ALL INTEGRATED CIRCUITS, DIODES D1, D2, AND ZK1.
- CAPACITORS C12, C14, C15, C24, C25, C27, CONNECTORS 10J1, 10J2, 10J3, 10J3, 10J5.
- POSITION OF TRANSISTORS Q2, Q3, Q3, Q4.
- DS1 - 1 SELECTS SOUNDS/NOTES
- 2 SELECTS SPEECH/NO SPEECH (W9/W1)
- W1 - SPEECH MODULE STATUS
- IN - SPEECH MODULE NOT ATTACHED
- OUT - SPEECH MODULE ATTACHED
- W14 - MPU INTERNAL RAM ENABLE
- W7 & W8 - MEMORY MAP CONTROL
- W12 & W13 - P87 STATUS CONTROL (W13 NEVER USED)
- W4 & W9 - P85 STATUS CONTROL
6. SOLDERED ON TOP OF BOARD
- INSTALL THESE JUMPERS FOR FOLLOWING GAMES:
- W15, W8, W12, W4, W1, W3, W6, W11 FOR:
 

WORLD CUP		
DISCO FEVER		
CONTACT POKER/NO		SOUND ROM 1
PHOENIX		
ARISTOCRAT SHUFFLE		
POPMPLI SHUFFLE		
KING TUT SHUFFLE		
TAURUS SHUFFLE		
- W15, W8, W12, W4, W1, W2, W5, W10, FOR:
 

FLASH		
STELLAR WARS		
TRI ZONE		SOUND ROM 1
TIME WARP		5A-9198
- W7, W15, W9, W1. (SEE NOTE #5) W2, W5, W10 FOR:
 

GORGAR		SOUND ROM 2	5A-9198
--------	--	-------------	---------
- IC12 SELECTION STRAPPING:
 

(2K x 8)	(1K x 8)	(512 x 8)
W2	W3	W3
W2 IN	W3 IN	W3 IN
W2	W3	W3

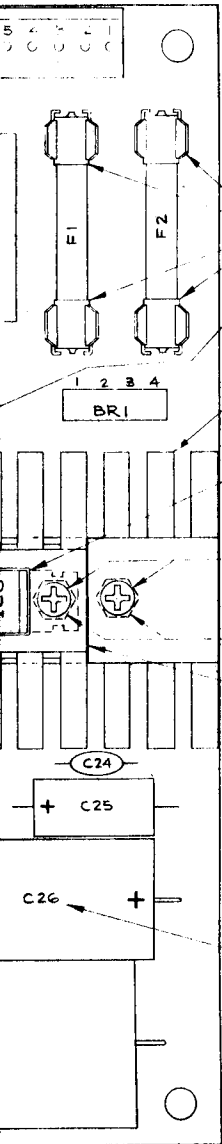

TOLERANCES		QTY.	ASSEMBLE ON
UNLESS OTHERWISE SPECIFIED:			
FRACTIONAL	±1/64"		
DECIMAL	±.0005"		
HOLE DIA.	±.008 - .0005"		
ANGULAR	±1/2°		
CONCENTRICITY	±1/8" .0005"		
SCREW THREADS	CLASS 2		
MATERIAL		HEAT TREATMENT	FINISH
DATE: 9-23-79		SCALE: 2:1	FINISH: D-8223
<b>WILLIAMS ELECTRONICS, INC.</b> 3401 N. CALIFORNIA CHICAGO, ILL. 60618 267-2240 <b>NAME: SOUND BOARD SUB-ASSEM</b>			





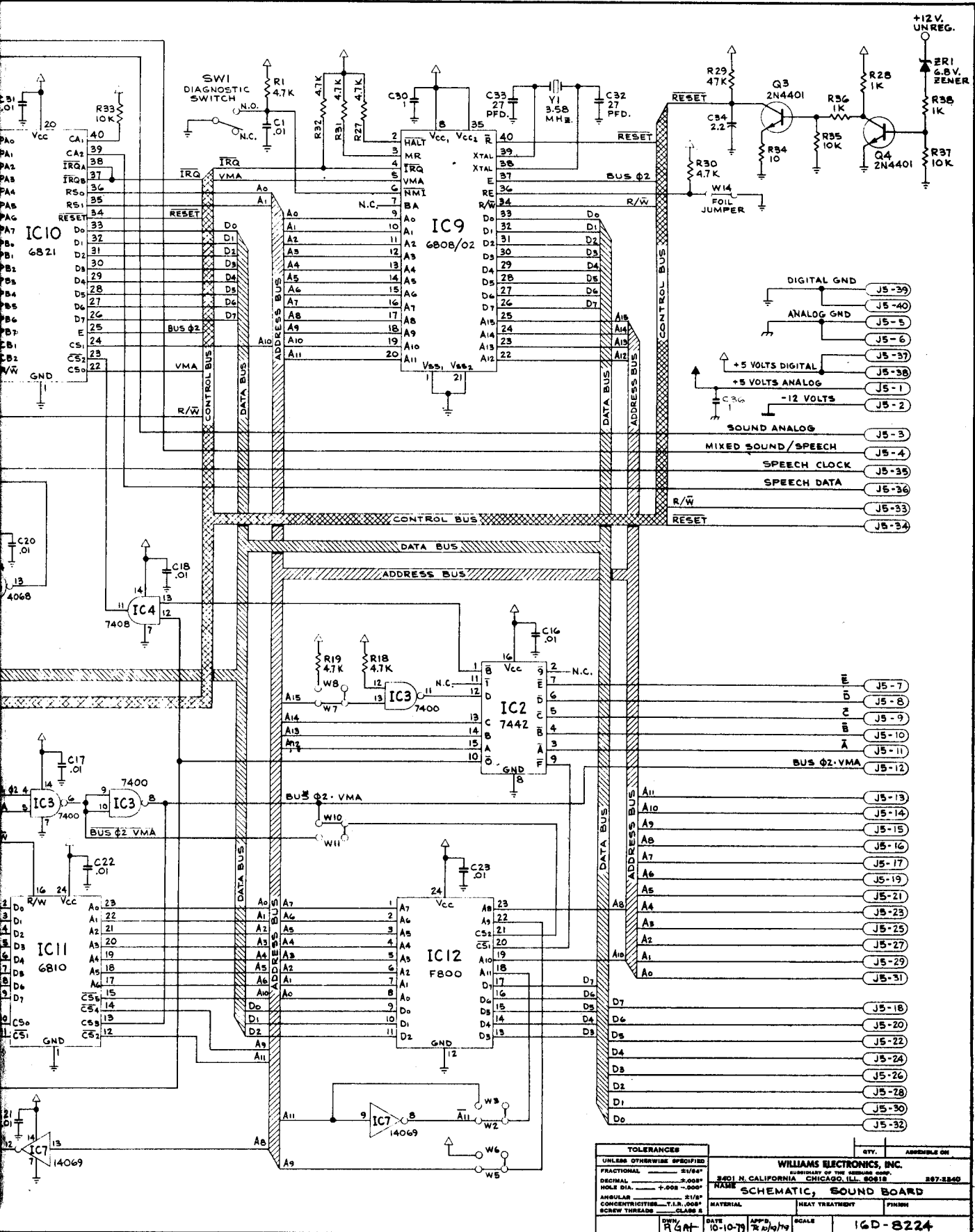

TOLERANCES		QTY.	AVAILABLE ON
UNLESS OTHERWISE SPECIFIED			
FRACTIONAL	±1/64"		
DECIMAL	±.0005"		
HOLE DIA.	+0.008 -0.0005"		
ANGULAR	±1/8°		
CONCENTRICITY	T.I.R., .0005"		
SCREW THREADS	CLASS 2		
DATE	10-10-79	APP'D.	SCALE
DWN.	RGA	DATE	SCALE

<b>WILLIAMS ELECTRONICS, INC.</b>			
SUBSIDIARY OF THE REEBING CORP.			
2401 N. CALIFORNIA - CHICAGO, ILL. 60618		867-8840	
NAME <b>SCHEMATIC, SOUND BOARD</b>			
MATERIAL	HEAT TREATMENT	FINISH	
16D-8224			

Sound Board Logic Diagram  
17



BILL OF MATERIAL

ITEM NO.	PART NO.	PART DESIGNATION	DESCRIPTION	REQD. NO.
1	IC-2001-148-2		BARE P.C. BOARD	1
2	5A-9334	IC1	3417 CONTINUOUSLY VARIABLE SLOPE DELTA MODULATOR	1
3	5A-9321	IC2, IC3	1458 DUAL OP-AMP.	2
4	5A-8992	R1, R4, R22, R25	RESISTOR, FC, 1/4 WATT	4
5	5A 8776	R2	RESISTOR, FC, 1/4 WATT	1
6	5A-8983	R3	RESISTOR, FC, 1/4 WATT	1
7	5B-8817	R5, R16	RESISTOR, FC, 1/4 WATT	2
8	5A-8773	R6	RESISTOR, FC, 1/4 WATT	1
9	5A-9353	R7	RESISTOR, FC, 1/4 WATT	1
10	5A-9324	R9, R10, R11, R15, R18, R19	RESISTOR, FC, 1/4 WATT	6
11	5B-8997	R12, R13	RESISTOR, FC, 1/4 WATT	2
12	5A-8772	R14, R17	RESISTOR, FC, 1/4 WATT	2
13	5A-9314	R20	RESISTOR, FC, 1/4 WATT	1
14	5A-9331	R21	RESISTOR, FC, 1/4 WATT	1
15	5A-9185	R8	POTENTIOMETER, 5K OHM	1
16	5A-9218	R24	RESISTOR, FC, 1/4 WATT	1
17	5A-8984	R25, R27	RESISTOR, FC, 1/4 WATT	1
18	5A-9356	R26	RESISTOR, FC, 1/4 WATT	1
19	5A-9031	C1	CAPACITOR, TANTALUM, 1 MFD. 20% 25 VOLT	1
20	5A-8980	C2, C3, C5, C7, C8, C9, C13 THRU C16	CAPACITOR, CERAMIC, .01 MFD. +80% -20% 50 VOLT	10
21	5A-9030	C4	CAPACITOR, CERAMIC, .047 MFD. 20% 50 VOLT	1
22	5A-9347	C6	CAPACITOR, CERAMIC, 1800 PFD. 5% 50 VOLT	1
23	5A-9346	C10	CAPACITOR, CERAMIC, 1200 PFD. 5% 50 VOLT	1
24	5A-9348	C11	CAPACITOR, CERAMIC, 4700 PFD. 5% 50 VOLT	1
25	5A-9343	C12	CAPACITOR, ELECTROLYTIC, 10 MFD. 20% 25 VOLT LOW LEAK	1
26	5A-9263	C17	CAPACITOR, .33 MFD. 20% 200 VOLT	1
27	5A-8996	C18, C19	CAPACITOR, CERAMIC, .1 MFD. 20% 25 VOLT	2
28	5A-9004		24 PIN SOCKET	4
29	5A 9354	J1	RIBBON CABLE ASSEMBLY	1

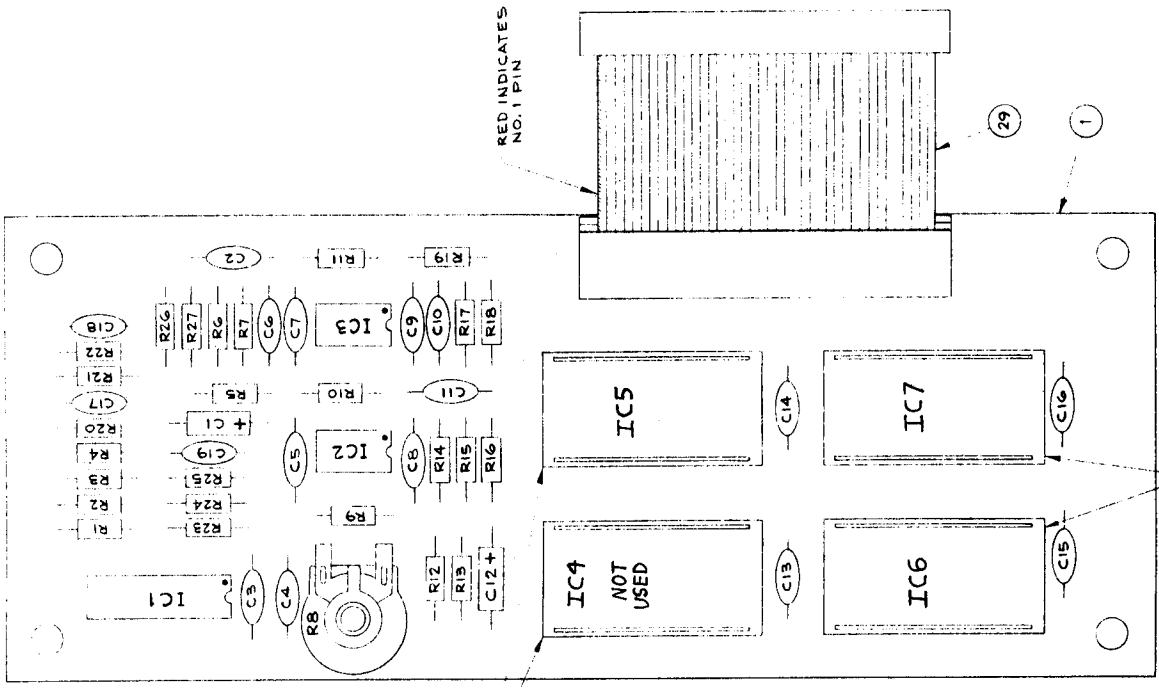

TOLERANCES UNLESS OTHERWISE SPECIFIED

FRACTIONAL .1 .125 .156 .2 .25 .3125 .375 .5 .625 .75 .875 1

DECIMAL .001 .002 .003 .004 .005 .006 .007 .008 .009 .010 .012 .015 .020 .025 .030 .0375 .045 .050 .0625 .075 .090 .100 .125 .150 .1875 .200 .250 .300 .375 .450 .500 .625 .750 .900 1.000

ANGULAR .1 .15 .2 .25 .3 .375 .45 .5 .6 .75 .9 1.0 1.25 1.5 1.75 2.0 2.25 2.5 2.75 3.0 3.25 3.5 3.75 4.0 4.5 5.0 5.5 6.0 6.5 7.0 7.5 8.0 8.5 9.0 9.5 10.0

CONCENTRICITY .1 .15 .2 .25 .3 .375 .45 .5 .6 .75 .9 1.0 1.25 1.5 1.75 2.0 2.25 2.5 2.75 3.0 3.25 3.5 3.75 4.0 4.5 5.0 5.5 6.0 6.5 7.0 7.5 8.0 8.5 9.0 9.5 10.0

SCREW THREADS PER ANSI B1.13-1

DATE 9-28-74

SCALE 2:1

REV. R4

ASSEMBLY ON

WILLIAMS ELECTRONICS, INC.  
 3401 N. CALIFORNIA  
 CHICAGO, ILL. 60618

NAME SPEECH MODULE

ASSEMBLY PART

REVISION LETTER

BY

REVISION

C-8225

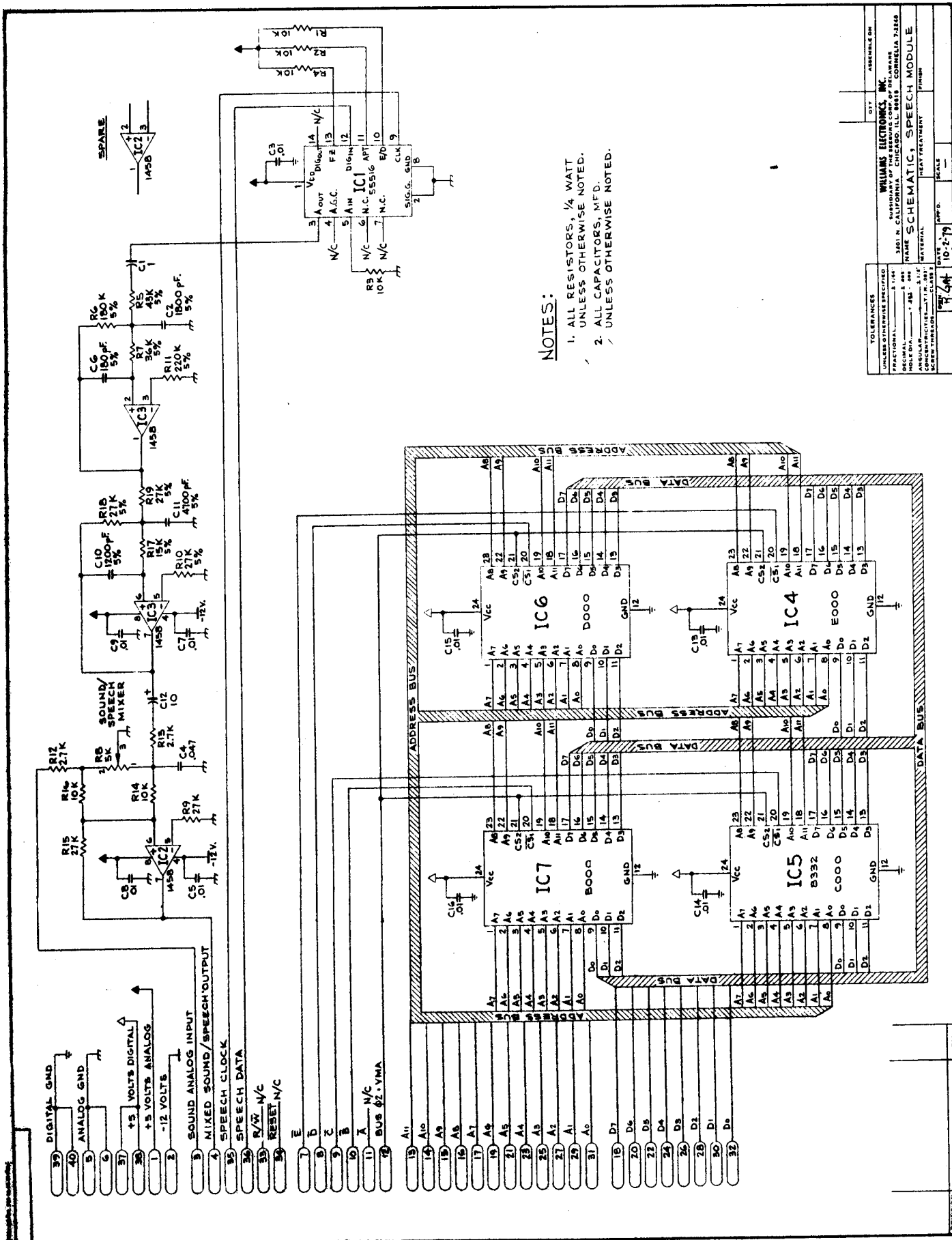

PLAYERS #1 & #3

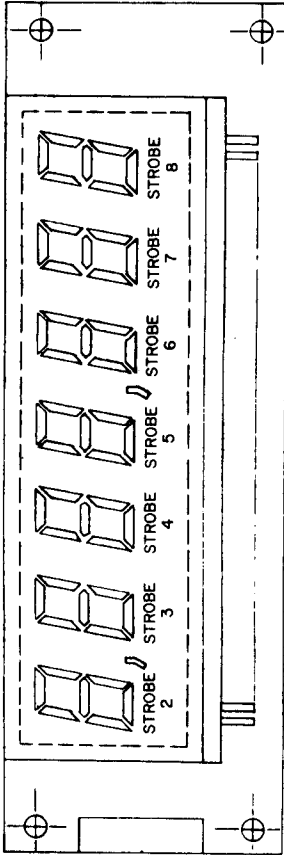

5J1  
5J3

PLAYERS #2 & #4

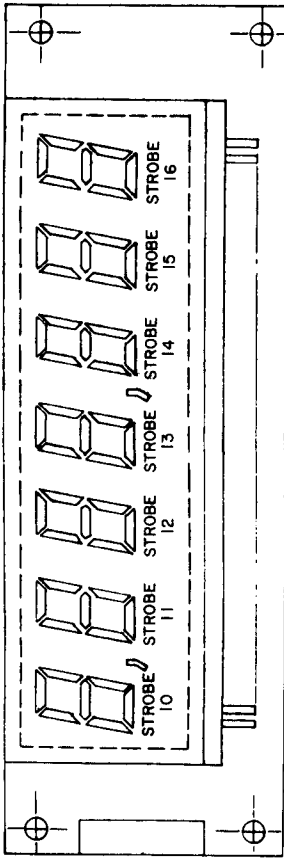

5J2  
5J4

4J1/5J1 (PLAYER 1)  
4J3/5J3 (PLAYER 3)

- 1 100,000's
- 2 -100V KEEP ALIVE
- 3 1,000,000's
- 4 f SEGMENT
- 5 N/C
- 6 g SEGMENT
- 7 +100V (N/C)
- 8 e SEGMENT
- 9 10,000's
- 10 d SEGMENT
- 11 1,000's
- 12 +100V KEEP ALIVE
- 13 100's
- 14 COMMA
- 15 10's
- 16 c SEGMENT
- 17 N/C
- 18 b SEGMENT
- 19 UNITS
- 20 a SEGMENT

4J2/5J2 (PLAYER 2)  
4J4/5J4 (PLAYER 4)

- 1 100,000's
- 2 -100V KEEP ALIVE
- 3 1,000,000's
- 4 f SEGMENT
- 5 N/C
- 6 g SEGMENT
- 7 +100V (N/C)
- 8 e SEGMENT
- 9 10,000's
- 10 d SEGMENT
- 11 1,000's
- 12 +100V KEEP ALIVE
- 13 100's
- 14 COMMA
- 15 10's
- 16 c SEGMENT
- 17 N/C
- 18 b SEGMENT
- 19 UNITS
- 20 a SEGMENT

4J8/5J5 (CREDIT/MATCH)

- 1 f Segment (Credit)
- 2 -100V Keep Alive
- 3 e' Segment
- 4 g' Segment
- 5 c' Segment
- 6 d' Segment
- 7 b' Segment
- 8 10's
- 9 Units
- 10 a' Segment
- 11 e Segment
- 12 f Segment
- 13 10's
- 14 d Segment
- 15 +100V Keep Alive
- 16 c Segment
- 17 g Segment
- 18 b Segment
- 19 Units
- 20 a Segment

Credit

DETAIL A  
4J1 - 4J4, 4J8  
5J1 - 5J5  
CONNECTORS

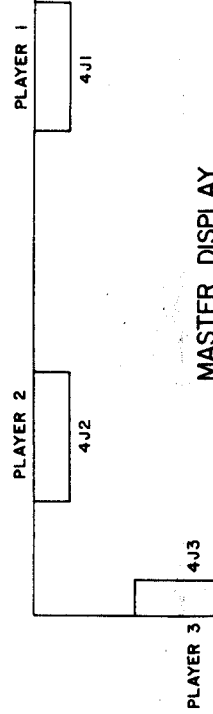
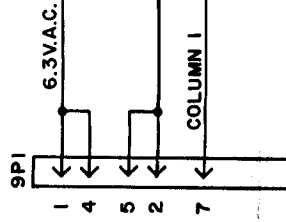
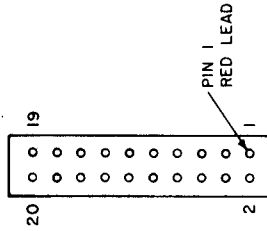



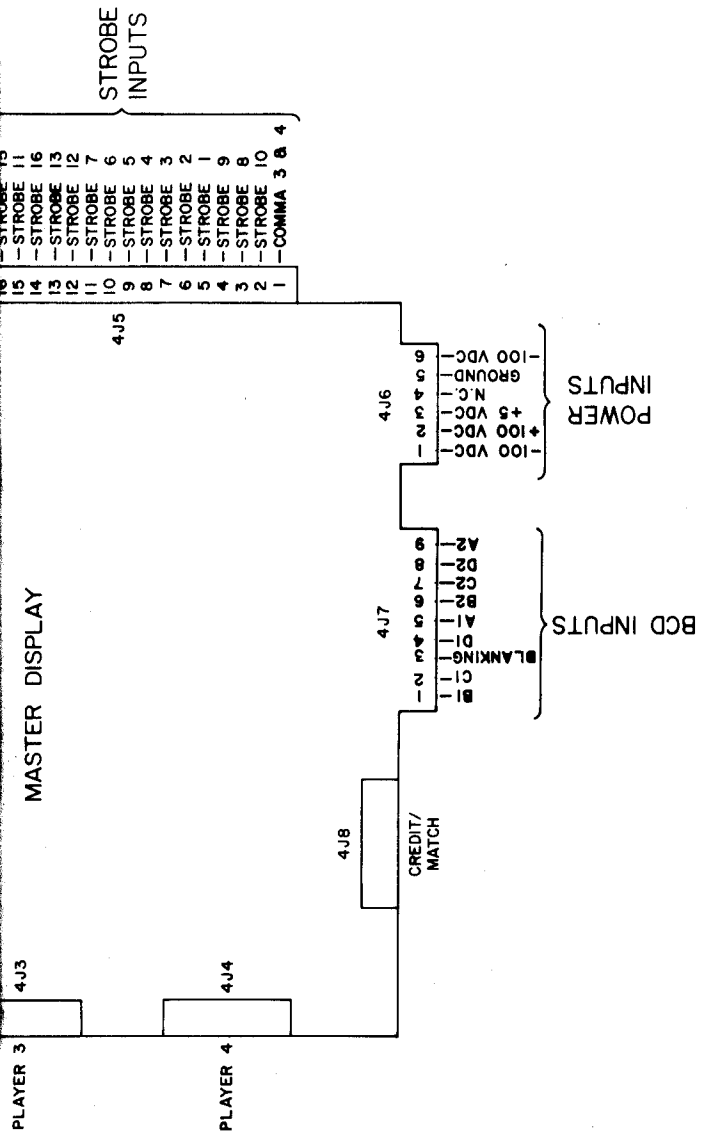
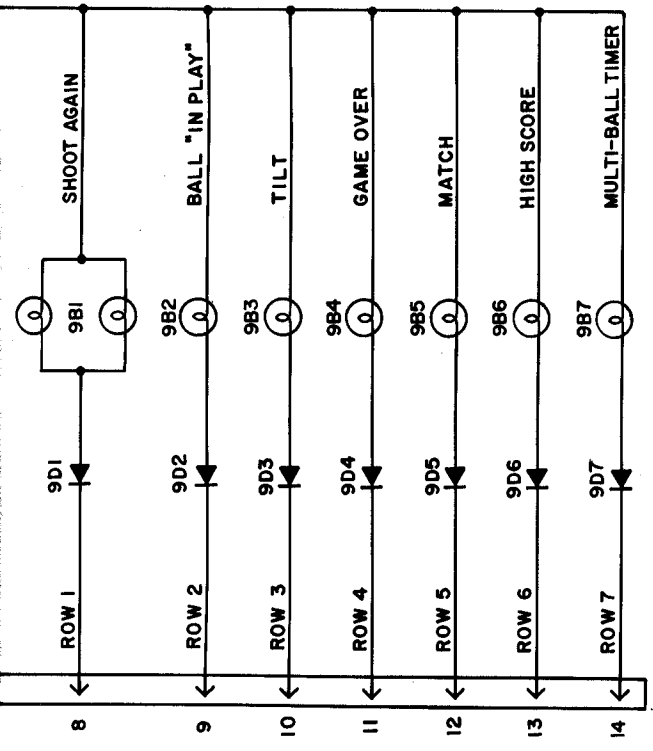

CREDITS / BALL IN PLAY

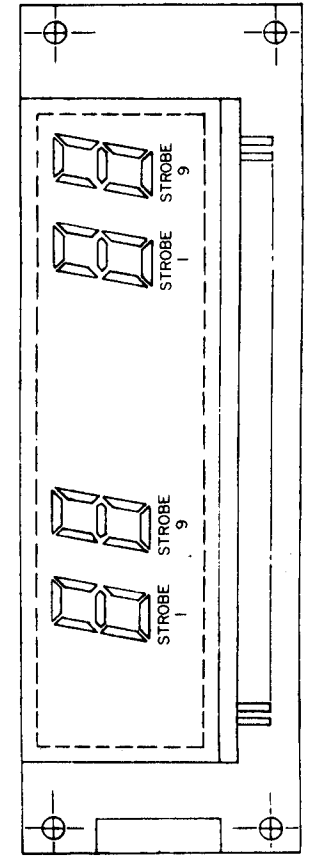

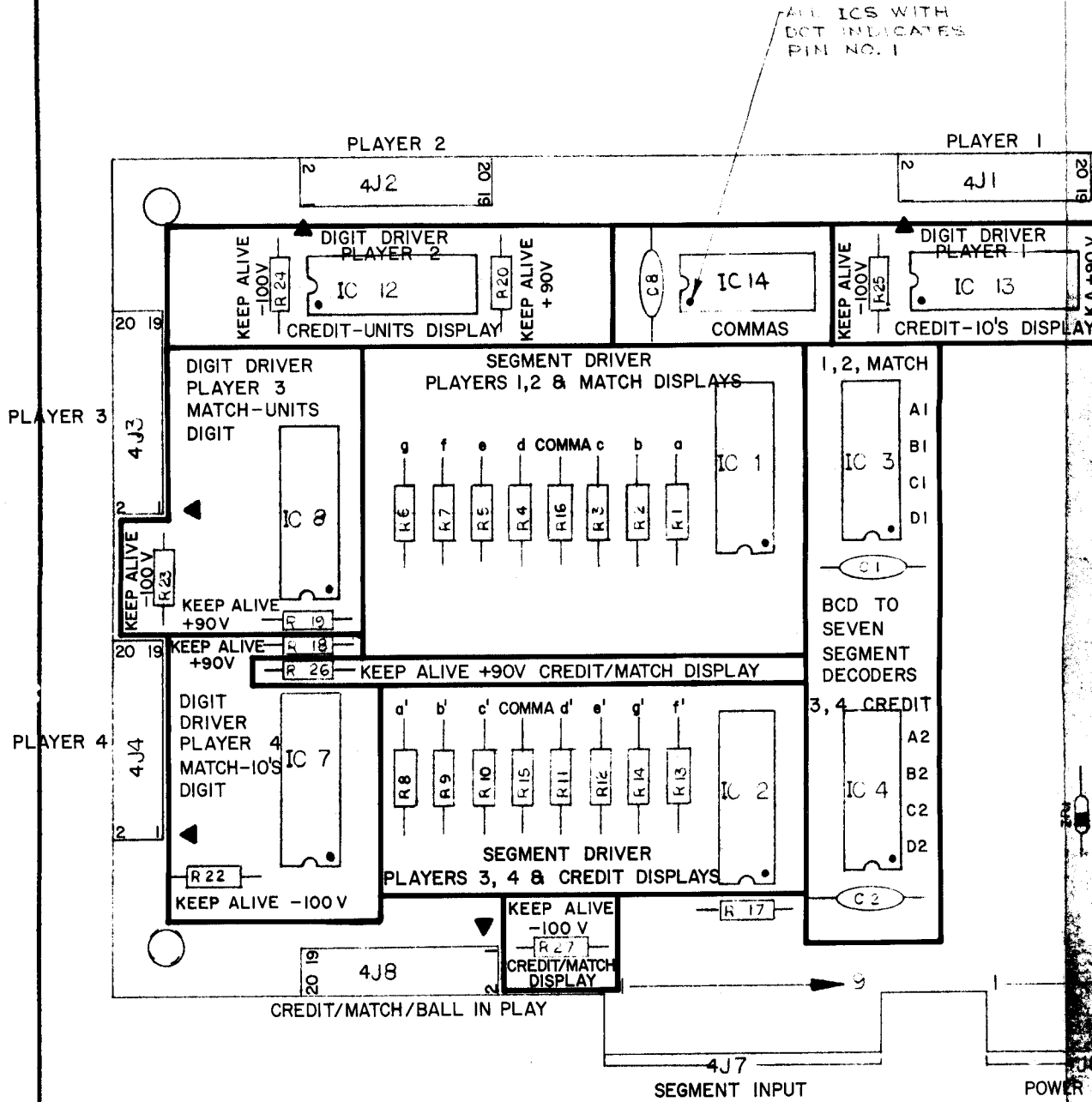

REVISION LETTER	REVISION	BY

# BILL OF MATERIAL

ITEM NO.	PART NO.	PART DESIGNATION	DESCRIPTION	REQ'D U.D.
1	IC-200F-152-B		BARE P.C. BOARD	1
2	5A-8971	IC 9, IC 10, IC 11	MC14069 HEX. INVERTER	3
3	5A-8970	IC 3, IC 4	MC14543 BCD TO SEVEN SEGMENT LATCH/DECODER/DRIVER	2
4	5A-8969	IC 1, IC 2	UDN-7180 GAS DISCHARGE DISPLAY SEGMENT DRIVER	2
5	5A-8968	IC 7, IC 8, IC 12, IC 13	UDN-6184A OR UDN-618A GAS DISCHARGE DISPLAY SEGMENT DR.	4
6		IC 14	MC14081 QUAD 2-INPUT AND GATE	1
7	5B-8981	R1-R14	RESISTOR, FC, 10K OHM 10% 1/2 WATT	14
8	5A-9135	ZR1	IN4740A ZENER DIODE 10V, 5% 1W	1
9	5A-8980	C1, C2, C5 THRU C8	CAPACITOR CERAMIC, 01 MFL. 50V	6
10		W2, W4	JUMPER #22 GA SOLID WIRE	2
11	5A-9086	R17	RESISTOR, FC, 6.8K OHM 10% 1/4 WATT	1
12	5B-8982	R18 THRU R27	RESISTOR, FC, 3 MEG. OHM 10% 1/4 WATT	10
13		J6, J1 THRU J4	20 PIN RIBBON HEADER	5
14		R15, R16	RESISTOR, 15K OHM, 10% 1/2 WATT	2

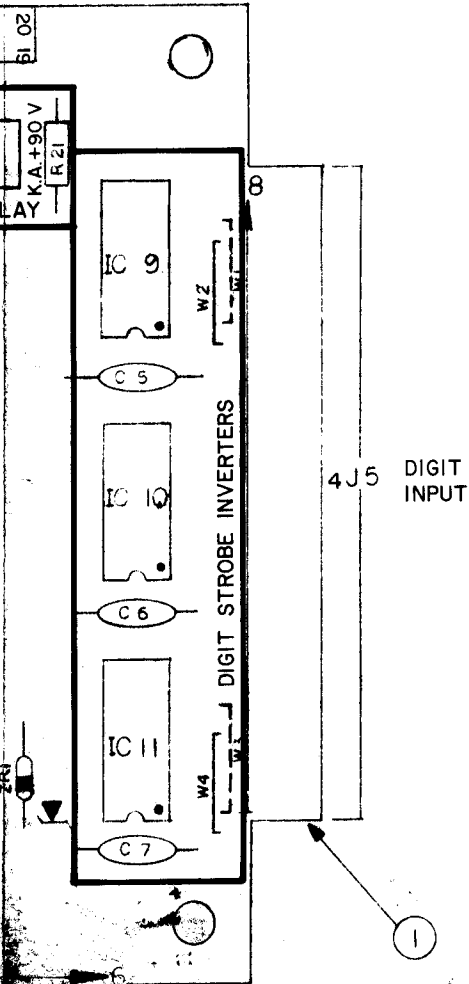

### DIGIT CROSS REFERENCE

DIGIT	7-SEGMENT DECODER/DRIVER	STROBE (DRIVER)
Credit 10's	IC4/IC2	1 (IC13)
Credit Units	IC4/IC2	9 (IC12)
Match 10's	IC3/IC1	1 (IC7)
Match Units	IC3/IC1	9 (IC8)
#1 1,000,000	IC3/IC1	2 (IC13)
#1 100,000's	IC3/IC1	3 (IC13)
#1 10,000's	IC3/IC1	4 (IC13)
#1 1,000's	IC3/IC1	5 (IC13)
#1 100's	IC3/IC1	6 (IC13)
#1 10's	IC3/IC1	7 (IC13)
#1 Units	IC3/IC1	8 (IC13)
#2 1,000,000's	IC3/IC1	10 (IC12)
#2 100,000's	IC3/IC1	11 (IC12)
#2 10,000's	IC3/IC1	12 (IC12)
#2 1,000's	IC3/IC1	13 (IC12)
#2 100's	IC3/IC1	14 (IC12)
#2 10's	IC3/IC1	15 (IC12)
#2 Units	IC3/IC1	16 (IC12)
#3 1,000,000's	IC4/IC2	2 (IC8)
#3 100,000's	IC4/IC2	3 (IC8)
#3 10,000's	IC4/IC2	4 (IC8)
#3 1,000's	IC4/IC2	5 (IC8)
#3 100's	IC4/IC2	6 (IC8)
#3 10's	IC4/IC2	7 (IC8)
#3 Units	IC4/IC2	8 (IC8)
#4 1,000,000's	IC4/IC2	10 (IC7)
#4 100,000's	IC4/IC2	11 (IC7)
#4 10,000's	IC4/IC2	12 (IC7)
#4 1,000's	IC4/IC2	13 (IC7)
#4 100's	IC4/IC2	14 (IC7)
#4 10's	IC4/IC2	15 (IC7)
#4 Units	IC4/IC2	16 (IC7)
#1 Comma	-/IC1	2.5 (IC13)
#2 Comma	-/IC2	10, 13 (IC12)
#3 Comma	-/IC1	2.5 (IC8)
#4 Comma	-/IC2	10, 13 (IC7)

TOLERANCES		QTY.	ASSEMBLE ON
UNLESS OTHERWISE SPECIFIED			
FRACTIONAL	± 1/64"	<b>WILLIAMS ELECTRONICS, INC.</b> SUBSIDIARY OF THE SEEBURG CORP. OF DELAWARE 3401 N. CALIFORNIA CHICAGO, ILL. 60618 CORNELIA 7-2240	
DECIMAL	± .005"		
HOLE DIA.	+ .002 - .000"		
ANGULAR	± 1/2°		
CONCENTRICITIES	T.I.R. .005"		
SCREW THREADS	CLASS 2	NAME <b>MASTER DISPLAY BOARD ASSEMBLY</b> MATERIAL _____ HEAT TREATMENT _____ FINISH _____	
DWN. <b>G.H.</b>	DATE <b>5-23-80</b>	APP'D.	SCALE <b>2:1 5/9/80</b>